

El Paso MPO Regional Mobility Strategy (RMS) Travel Demand Model

2017 Base Year

final report

prepared for

El Paso MPO

prepared by

Cambridge Systematics, Inc.

with

Alliance Transportation Group

final report

El Paso MPO Regional Mobility Strategy (RMS) Travel Demand Model

2017 Base Year

prepared for

El Paso MPO

prepared by

Cambridge Systematics, Inc.
505 East Huntland Drive, Suite 550
Austin, TX 78752

with

Alliance Transportation Group

date

July 15, 2021 (revised October 19, 2022)

Table of Contents

1.0	Introduction	7
1.1	Data Sources	9
2.0	TAZs.....	10
3.0	Roadway Network	13
3.1	Roadway Network Structure	13
3.1.1	Input and Output Networks	13
3.2	Network Attributes.....	14
3.2.1	Functional Classification	16
3.2.2	Bicycle Facility Type	18
3.2.3	Area Type	18
3.2.4	Link Speeds	19
3.2.5	Link Capacities.....	20
3.2.6	Toll and HOV Coding.....	21
3.2.7	Routable Network	22
4.0	Transit Network	23
4.1	Transit / Roadway Linkage	23
4.2	Transit Route System	23
4.2.1	Route System Attributes	24
4.2.2	Base Year Transit Routes.....	25
4.3	Transit Roadway Network.....	26
4.3.1	Transit Travel Time	26
4.3.2	Walk Access and Egress	27
4.3.3	Walk Access/Egress Adjustment	27
4.3.4	Drive Access	28
4.4	Transit Pathbuilding	28
5.0	External Travel.....	30
5.1	External Station Locations	30
5.2	Base Year External Travel.....	31
5.2.1	External Station Volumes	31
5.2.2	Internal-External and External-Internal Trips.....	32
5.2.3	External-External Trips	32
5.2.4	External Station Forecasting.....	33
6.0	Trip Generation.....	34

6.1	Socioeconomic Input Data	34
6.1.1	Household and Population Data	34
6.1.2	Employment and Employment Data	35
6.1.3	Socio-Economic Data Summary	36
6.2	Trip Purposes	36
6.3	Production Rates	38
6.4	Attraction Rates	45
6.5	Income Segmentation	46
6.6	Special Generators	47
6.6.1	University of Texas at El Paso (UTEP)	47
6.6.2	Fort Bliss	50
6.6.3	El Paso International Airport	51
6.6.4	Special Generator Forecasting	52
6.7	Trip Balancing	53
7.0	Trip Distribution	54
7.1	Peak and Off-peak Period Definitions	54
7.2	Gravity Model	54
7.2.1	Friction Factors	55
8.0	Vehicle Availability Model	56
8.1	Variables	56
8.2	Model Estimation	57
8.3	Model Calibration	58
9.0	Mode Choice	60
9.1	Observed Mode Shares	60
9.1.1	Non-Transit Mode Shares	60
9.1.2	Observed Transit Trips	61
9.2	Mode Choice Model Structure	64
9.2.1	Market Segmentation	66
9.2.2	Production and Attraction Density Variables	68
9.2.3	Model Specification	68
9.2.4	Auto Occupancy	73
10.0	Trip Assignment	74
10.1	Time of Day	74
10.1.1	Time Period Definitions	74
10.1.2	Directional Time of Day Factors	74
10.2	Traffic Assignment	75

10.2.1	Closure Criteria	75
10.2.2	Impedance Calculations	76
10.2.3	Volume-Delay Functions.....	76
10.2.4	Multi-Class Assignment	77
10.3	Speed Feedback.....	79
10.3.1	Method of Successive Averages	80
10.3.2	Initial Speeds and Borrowed Feedback Results	81
10.3.3	Convergence Criteria	81
10.3.4	Shortest Path Root Mean Square Error.....	81
10.3.5	Application of Speed Feedback for Alternatives Analysis	83
10.4	Transit Assignment	83
11.0	Calibration and Validation	85
11.1	Trip Generation Calibration.....	85
11.2	Trip Distribution Calibration	85
11.2.1	Trip Distribution Calibration	85
11.3	Mode Choice Calibration	89
11.4	Traffic Assignment Validation	91
11.4.1	Overall Activity Level.....	91
11.4.2	Measures of Error	92
11.4.3	Screenline Analysis.....	94
11.5	Transit Assignment Validation	97
Appendix A.	LOCUS Location Based Services Data.....	A-1
Appendix B.	Transit Delay Parameters.....	B-1
Appendix C.	NAICS Codes	C-1

List of Tables

Table 2.1	Data Dictionary for RMS Model TAZ file.....	10
Table 3.1	Input Network Link Fields	15
Table 3.2	Input Network Node Fields	16
Table 3.3	Functional Classes	16
Table 3.4	Bicycle Facility Type	18
Table 3.5	Area Type Ranges.....	19
Table 3.6	Free-flow Speed Lookup Table	20
Table 3.7	Hourly Lane Capacity Lookup Table	20
Table 3.8	Toll Table Fields	21
Table 4.1	Route Attributes	24
Table 4.2	Transit Network Mode Values	24
Table 4.3	Route Stop Attributes.....	25
Table 4.4	Key fields in Transit Line Layer	27
Table 4.5	Minimum Walk Access/Egress Times by Market Segment	28
Table 4.6	Transit Pathbuilding Weights.....	29
Table 5.1	External Travel Assumptions.....	31
Table 5.2	External Trip Truck Classification Shares	32
Table 5.3	External Trip Seed Matrix	33
Table 6.1	Income Group Definitions	35
Table 6.2	Employment Type Categories	36
Table 6.3	Socio-Economic Data Summary.....	36
Table 6.4	HBW Trip Production Rates (Work).....	39
Table 6.5	HNWR Trip Production Rates (Retail)	40
Table 6.6	HNWE1 Trip Production Rates (Kindergarten to Grade 12).....	41
Table 6.7	HNWE2 Trip Production Rates (College/University)	42
Table 6.8	HNWO Trip Production Rates (Other)	43
Table 6.9	NHB Trip Production Rates	44
Table 6.10	Trip Attraction Rates	45
Table 6.11	UTEP Special Generator Values	50
Table 6.12	Fort Bliss Special Generator Trip Distribution	51
Table 6.13	Airport Special Generator Trip Distribution.....	51
Table 7.1	Trip Distribution Time of Day Factors	54
Table 7.2	Gravity Model Friction Factors (Peak)	55
Table 7.3	Gravity Model Friction Factors (Off-Peak).....	55
Table 8.1	Utility Parameters for Accessibility Variables	57

Table 8.2	Vehicle Availability Model Estimation Results	58
Table 8.3	Theta Values for the Vehicle Availability Model	59
Table 8.4	Vehicle Sufficiency Validation.....	59
Table 9.1	Non-Transit Trip Targets	61
Table 9.2	2017 Fixed Route Boardings	62
Table 9.3	Observed Walk and Drive Access Shares	62
Table 9.4	Resulting Transit Trip Targets	64
Table 9.5	Walk Access and Egress Market Segments	67
Table 9.6	Walk Segments Sample Output	68
Table 9.7	Mode Choice Model Coefficients.....	70
Table 9.8	Peak Mode Choice Model Constants by Income	71
Table 9.9	Off-peak Mode Choice Model Constants by Income.....	72
Table 9.10	Mode Choice Model Constants by Vehicle Sufficiency	73
Table 10.1	Travel Model Time Periods.....	74
Table 10.2	Pre-Assignment Directional Time of Day Factors	75
Table 10.3	Volume Delay Function Lookup Table (Alpha / Beta)	77
Table 10.4	Perceived Value of Time by Vehicle Class.....	78
Table 11.1	Average Daily Travel Times by Trip Purpose.....	86
Table 11.2	Mode Choice Calibration Targets – Number of Trips	90
Table 11.3	Mode Choice Model Results – Number of Trips.....	91
Table 11.4	Mode Choice Calibration Results – Percent Difference	91
Table 11.5	Regional Modeled Volumes and VMT vs. Counts.....	92
Table 11.6	RMSE Statistics by Link Type	94
Table 11.7	RMSE Statistics, by Volume Group.....	94
Table 11.8	RMS Model Screenline Analysis	95
Table 11.9	Transit Assignment Results	98
Table B.1	Peak Local Transit Delay Factors.....	B-1
Table B.2	Peak Express Transit Delay Factors	B-1
Table B.3	Peak Premium Transit Delay Factors.....	B-1
Table B.4	Off-Peak Local Transit Delay Factors.....	B-2
Table B.5	Off-Peak Express Transit Delay Factors	B-2
Table B.6	Off-Peak Premium Transit Delay Factors.....	B-2
Table C.1	Employment Type Definition.....	C-1

List of Figures

Figure 1.1	El Paso MPO Travel Demand Model Structure	8
Figure 3.1	Example Model Run Directory Structure	14
Figure 4.1	Connections between the Route System and Transit Line Layer	23
Figure 4.2	El Paso Base Year Transit Routes	26
Figure 5.1	El Paso External Station Locations	30
Figure 6.1	UTEP Traffic Analysis Zones	48
Figure 6.2	Fort Bliss and Airport Zones (Overview)	52
Figure 6.3	Fort Bliss and Airport Zones (Detail)	52
Figure 9.1	2017 Park-n-Ride Locations	63
Figure 9.2	Nested Logit Mode Choice Structure	66
Figure 10.1	Feedback Process	80
Figure 10.2	Peak Period % RMSE by Iteration	82
Figure 11.1	Home-Based Work Trip Length Frequency Distribution	87
Figure 11.2	Home-Based Non-Work Education 1 Trip Length Frequency Distribution	87
Figure 11.3	Home-Based Non-Work Education 2 Trip Length Frequency Distribution	88
Figure 11.4	Home-Based Non-Work Retail Trip Length Frequency Distribution	88
Figure 11.5	Home-Based Non-Work Other Trip Length Frequency Distribution	89
Figure 11.6	Non-Home Based Trip Length Frequency Distribution	89
Figure 11.7	Mode Choice Calibration Methods	90
Figure 11.8	Model Volume/Count Comparison	93
Figure 11.9	RMS Model Screenlines	96
Figure 11.10	RMS Model Screenline Analysis	97
Figure 11.11	Route Group Definitions	98

1.0 Introduction

The El Paso MPO and its affiliated stakeholders use the El Paso MPO Regional Travel Demand Model as a tool to forecast traffic and travel in communities throughout the region. The primary purpose of the travel model is to support the Metropolitan Transportation Plan (MTP). The model can support evaluation of proposed roadway and transit projects, help evaluate potential impacts of proposed development projects, and support various other studies of the region, subareas, corridors, and other planning activities. The model has been calibrated to reflect a base year of 2017 and contains future year data reflecting forecast 2050 conditions. Interim year data representing several intermediate timeframes is also maintained in the travel model dataset.

The previous version of the model, named the Destino Model, featured a 2012 base year and 2045 forecast year. This version of the model, named the Regional Mobility Strategy (RMS) Model, includes moderate changes to the Destino Model. Changes include updating the model base year to 2017, integrating the new TripCAL6 trip generation program, adding walk market segmentation sensitivity to the mode choice model, adding sensitivity to the mode choice model to better forecast bicycle trips, adding select link analysis capability to the trip assignment model, and calibrating and validating the various model components to a new base year.

Data sources include available census packages, a 2010-2011 Household Travel Survey, and a 2012 transit on-board survey. All of these data sources were accounted for in the 2012 base year Destino travel model with the exception of the more recent transit-onboard survey which replaces an older transit on-board survey data from the previous model update. This version of the model has also employed location based services (LBS) data in the calibration and validation of the trip generation and distribution models.

The RMS Model's process and functions are shown in the model flow diagram in **Figure 1.1**. It is a standard 4-step modeling process that is prevalent among travel models in small and medium-sized regions throughout the U.S.

Figure 1.1 El Paso MPO Travel Demand Model Structure

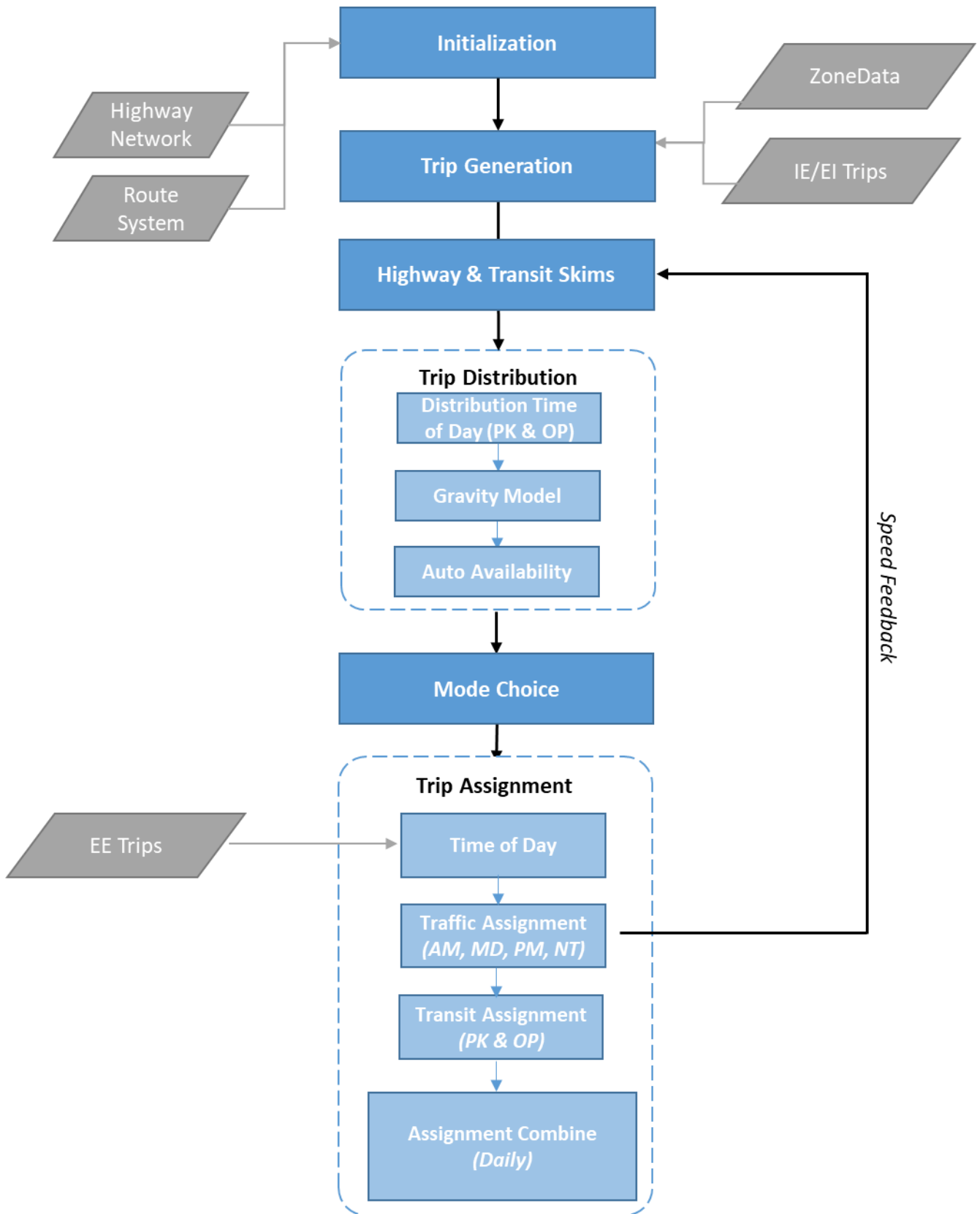

1.1 Data Sources

Travel behavior represented in the RMS Model was estimated in development of the Destino Model using data from a household travel survey (HTS) conducted in 2010-2011. HTS data were combined with data from an on-board transit survey conducted at a similar time. Because new HTS and on-board survey data were not available for this effort, other data sources have been used to calibrate and validate model components to the new 2017 base year.

- **El Paso Household Travel Survey Data (2010-2011)** were provided by the MPO for the development of the Destino Model and for reference in RMS model development. The data were used extensively in Destino model development and were frequently referenced in confirming or updating parameters in development of the RMS Model.
- **Transit On-Board Survey Data (2012)** were provided by the MPO for the development of the Destino Model and for reference in RMS model development. The data were used along with base year transit boarding data to develop observed transit by purpose, time period, and income group.
- **Traffic Counts (2017)** were obtained by the MPO and attached to the highway network for use in model validation.
- **Transit Boarding Data (2017)** were provided by transit operators in the region. Total boardings by route were used in calibration of mode choice as well as validation of transit assignment.
- **LOCUS Location Based Services (LBS) Data (2019)** served as an additional calibration and validation data source that supplemented the HTS dataset. LBS data is a licensed data product that provides trip patterns at the Census block group level. More information about the LOCUS data is provided in **Appendix A**.

In addition, data from the American Community Survey (ACS) and proprietary employer data obtained from InfoUSA were used to support development of demographic data.

2.0 TAZs

Traffic analysis zones (TAZ) are geographic boundaries that contain socioeconomic data used as the foundation for trip-making in the travel model. The TAZ layer is formatted as a polygon layer and is based on US Census Block geography. The size and number of TAZs in a particular area is primarily driven by the density of development but planned or expected future development also plays a role. Developed areas require a greater number of smaller zones, while rural un-developed areas are represented with larger zones. TAZs are attached to the roadway networks using zone centroids and centroid connectors that allow travelers access to the transportation system by simulating local and neighborhood streets.

TAZs are ideally but not always sized and shaped to provide a relatively homogeneous amount and type of activity within each zone. TAZ delineations traditionally follow the natural and manmade boundaries that tend to segregate different land uses. These boundaries include water features, bridges, roads, railroads, and other lines that form logical boundaries. Jurisdictional and Census boundaries often do not make for good TAZ delineations because they can be arbitrary in relation to the needs of the model; but they are usually desirable for data development and reporting functions.

The 2017 TAZ layer is based on the 2012 TAZ layer from the Destino model. Consequently, zone numbering has not changed between the two models. The zone system totals 869 TAZs, 848 of which are internal and 21 are external. The TAZ layer is contained in a TransCAD geographic file and is a required input to the travel model. A listing of required fields in the TAZ geographic file can be found in **Table 2.1**. By design, the geographic file contains all required socio-economic and demographic information used by the trip generation model.

All demographic data read by the model is contained directly on the TAZ geographic file. More details about demographic data development are provided in separate documents.

Table 2.1 Data Dictionary for RMS Model TAZ file

TAZ Fields	Description	Comment
ID	Unique TransCAD identifier	Must match the TAZ number
Area	Total TAZ area (square miles)	Maintained by TransCAD
TAZ	TAZ number	
Acres	Total TAZ area (acres)	
County	Texas or New Mexico	
Municipal	Jurisdiction (city or county) containing the TAZ	
District	District name for analysis	Used for Delphi Process
MPO_Boundary	Distinguishes between internal and external zones	
ATYPE_yy	Numeric area type ID (See Section 3.2.3)	yy represents a two-digit analysis year code (e.g., 17, 45)
POP_yy	Non-special generator population	
HHPOP_yy	Non-special generator household population	
GQPOP_yy	Non-special generator group quarter population	
HH_yy	Number of non-special generator households	

TAZ Fields	Description	Comment
HHSIZE_yy	Average household size	
MEDINC_yy	Median household income	
AVGWRK_yy	Average number of workers per household	
EMP_yy	Non-special generator total employment	
BASIC_yy	Non-special generator basic employment	
RETAIL_yy	Non-special generator retail employment	
SERVICE_yy	Non-special generator service employment	
EDY_yy	Non-special generator education employment	
K12_ENROLL_yy	Non-special generator school enrollment	
COLL_ENROLL_yy	Non-special generator college enrollment	
SGEN_yy	Includes a 1 to indicate internal special generator or external station zones	
SGZ_yy	Includes a 1 to indicate internal special generator zones	
SGZ_POP_yy	Special generator population	
SGZ_HH_yy	Special generator households	
SGZ_AVGHH_yy	Special generator average household size	
SGZ_MEDINC_yy	Special generator median household income	
SGZ_AVGWRK_yy	Special generator average number of workers per household	
SGZ_EMP_yy	Special generator total employment	
SGZ_BAS_yy	Special generator basic employment	
SGZ_RET_yy	Special generator retail employment	
SGZ_SER_yy	Special generator service employment	
SGZ_EDU_yy	Special generator education employment	
SGZ_K12ENR_yy	Special generator school enrollment	
SGZ_COLENR_yy	Special generator college enrollment	
AOP_NHB_yy	Add-on NHB trip productions (not used by the RMS Model, set to zero)	
AOA_NHB_yy	Add-on NHB trip attractions (not used by the RMS Model, set to zero)	
CMT_yy	Special generator description	
TOT_POP_yy	Total population	
TOT_HH_yy	Total households	
TOT_EMP_yy	Total employment	
TOT_BAS_yy	Total basic employment	
TOT_RET_yy	Total retail employment	
TOT_SER_yy	Total service employment	
TOT_EDU_yy	Total education employment	
SGP_HBW_yy	Special generator home-based work productions	

TAZ Fields	Description	Comment
SGP_HNWE1_yy	Special generator home-based education 1 productions	
SGP_HNWE2_yy	Special generation home-based education 2 productions	
SGP_HNWR_yy	Special generator home-based retail productions	
SGP_HNWO_yy	Special generator home-based other productions	
SGP_NHB_yy	Special generator non-home based productions	
SGP_LT_yy	Special generator light truck productions	
SGP_MT_yy	Special generator medium truck productions	
SGP_HT_yy	Special generator heavy truck productions	
SGP_EXTINT_yy	Special generator EI/IE productions	
SGA_HBW_yy	Special generator home-based work attractions	
SGA_HNWE1_yy	Special generator home-based education 1 attractions	
SGA_HNWE2_yy	Special generator home-based education 2 attractions	
SGA_HNWR_yy	Special generator home-based retail attractions	
SGA_HNWO_yy	Special generator home-based other attractions	
SGA_NHB_yy	Special generator non-home based attractions	
SGA_LT_yy	Special generator light truck attractions	
SGA_MT_yy	Special generator medium truck attractions	
SGA_HT_yy	Special generator heavy truck attractions	
SGA_EXTINT_yy	Special generator EI/IE attractions	

Note: The TAZ structure adopted by the El Paso MPO model differs from the standard TexPACK format used by some models in the state of Texas.

3.0 Roadway Network

The roadway network contains basic input information for use in the travel demand model and represents real-world conditions for the 2017 base year and expected conditions for future years or tested alternatives. The roadway networks are used in the model to distribute and route vehicle trips. The model networks provide a foundation for system performance analysis including vehicle miles of travel, congestion delay, level of service, and other performance measures. This section provides a description of the network attributes and lookup tables for the roadway networks. The assumptions and parameters identified herein are relevant for the model's 2017 base year network, but they generally apply to interim and forecast year networks as well.

The roadway network is a GIS-based representation of the street and highway system in the El Paso MPO modeling area. It also has designations for bicycle facilities including bike routes, bike lanes, and multi-use paths. It is one of the foundational components of the travel model as it serves to represent the supply side of the travel demand/transportation system relationship. As such, the establishment and review of detailed network attribute data was very important to the model's development. The network serves as:

- An input database containing roadway and non-motorized facility characteristics (such as facility type, number of lanes, area type, etc.);
- A foundation for the transit route system; and
- A data repository that can be used to store and view travel model results.

The roadway network is structured to contain data across multiple years. The roadway network prepared for the RMS Model is designed to maintain information about existing, as well as planned and proposed roadway, transit, and non-motorized projects. This allows the network to represent the 2017 base year, existing plus committed networks, planned forecast year networks, interim horizon year networks, and any other network scenarios desired within a single network database.

3.1 Roadway Network Structure

The RMS Model roadway network structure is a flexible data repository that hosts input and output data required by the travel model. This section describes the network file structure and defines attributes populated on the network. Input attributes and some output attributes are discussed herein. Additional output variables created by subsequent model steps are discussed in the associated sections of this report.

Input network attributes used by the travel model include functional class, area type (populated based on TAZs), number of lanes, and direction of flow. Each of these variables is addressed in the sections that follow. Values for these attributes have been populated on the roadway network file for the year 2017, 2050, and various interim years.

3.1.1 Input and Output Networks

The roadway network file contains travel model input data and also acts as a repository for both intermediate (e.g., speed and capacity) and final (e.g., traffic volumes) model data. For this reason, a separate output model network is created for each model scenario. This output network is created by making a copy of the input network and then modifying this network to contain data and results specific to each model run. This

copy of the roadway network is created and modified automatically by a network initialization step when the travel model is run.

The model's directory structure allows for a single input and output folder for each model scenario as shown in **Figure 3.1**. When the travel model is run, files located in the input directory are not modified by model macros. Instead, if a file is to be modified, it is copied to an output directory and only the copy is modified. One exception is the transit route system, which is modified in-place. This approach has several benefits, including:

- All input files relevant to the scenario are stored inside the scenario folder making locating files easier; and
- Because input files are not modified by the travel model macros, it is unlikely that important data present within input files will be inadvertently overwritten by travel model macros.

Figure 3.1 Example Model Run Directory Structure

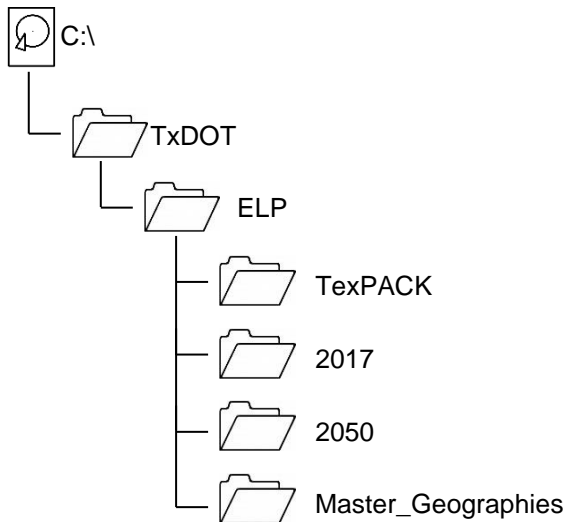

3.2 Network Attributes

The roadway network contains input attributes listed in **Table 3.1**. Additional fields can be added to the network by MPO staff or other users as desired using standard tools available in the TransCAD software. These additional fields will not be referenced by the travel model but can be used to aid in analysis of results.

In addition to link attributes, several attributes are included on the node layer of the roadway network file. Centroid nodes are identified by the ZONE attribute on the node layer. Node attributes are listed in **Table 3.2**.

Table 3.1 Input Network Link Fields

Field Name	Description	Comments
ID	TransCAD Unique ID	Maintained automatically by TransCAD
Dir	Link Direction of Flow	Direction of Flow
Length	Link Length in miles	Maintained automatically by TransCAD
TAZ	TAZ where link is located	
County	County where link is located	
Local_Stre	Optional Field indicating street name	
State_Syst	State system roadway name	
District	El Paso MPO District Assignment	
FUNCL_yy	Scenario-specific functional class (see Table 3.3 for definition)	yy represents a two-digit year code (e.g., 17, 50) or a string representing a scenario (e.g., CE)
LANES_AB/BA_yy	Scenario-specific directional number of through lanes	
DIV_yy	Flag denoting divided or undivided roadway (0=undivided; 1=divided) – not currently used in model	
ATYPE_yy	Link area type (populated during the model run)	
PKFB_AB/BA_yy	Peak directional speed from feedback loop	
OPFB_AB/BA_yy	Off-peak directional speed from feedback loop	
TrkProhib_yy	Truck Prohibition: null/0= Trucks Allowed; 1=Med/Hvy Trucks Prohibited,	
HOV_yy	HOV Restriction (no trucks allowed): 2=HOV2+; 3=HOV3+; null/0=no restriction	
Toll_SOV/HOV2/HOV3_PK/OP_yy	Tolls to be paid by vehicle class in 2017 dollars (SOV, HOV2,HOV3) and period (PK,OP), allowing testing of HOT lane concepts.	
Toll_LTK/MTK/HTK_PK/OP_yy	Tolls to be paid by vehicle class in 2017 dollars (LTK,MTK,HTK) and period (PK,OP), allowing testing of HOT lane concepts.	
BIKEFT_yy	Bicycle facility type representing bicycle comfort index.	
VAL_COUNT	Traffic count selected for use in validation	
VC_Auto/MT/HT	Vehicle class counts used to validate by vehicle class – not directly used by the model.	
MergelD	ID used to merge volumes on mainline and HOV/managed lanes when comparing to counts.	

Notes: Additional fields not included in this table may be present on the network but are not referenced by the travel model. The model creates numerous additional fields at runtime and places them on the output network. Examples include fields for Capacity, Alpha, and Beta. If such fields exist on the input network, their contents are overwritten in the output copy of the network.

Table 3.2 Input Network Node Fields

Field Name	Description	Comments
ID	Unique TransCAD ID	Maintained automatically by TransCAD. Note: The node ID value should be set to match the Zone number. This can be accomplished by either exporting the network file after modifying the ZONE field or running the Update Input Network utility available from the model interface.
TAZ	Traffic Analysis Zone Number	Populated only for centroid nodes (including external station nodes). Null for all non-centroid nodes.
ModelArea	Distinguishes between external nodes, internal nodes, and internal centroids	

3.2.1 Functional Classification

The Functional Class (FUNCL) variable on the roadway network is used to look up speed, capacity, and volume delay parameters. Functional class values used in the RMS Model are listed in **Table 3.3**. Functional classifications 51 and 61 are included for use in future scenario coding and are not present in the base year network.

Table 3.3 Functional Classes

Value	Functional Class
0	Centroid Connector
1	Interstate
2	Expressway
3	Principal Arterial
4	Minor Arterial
5	Collector & Frontage Road
6	(Not Used)
7	Local
20	Ramp
51	Transit Only
61	Bicycle Only

The following bullets provide a description of each functional class:

- **Centroid Connector** – These facilities are the means by which the trip and other data at the traffic analysis zone (TAZ) level are attached to the street system. Centroid connectors are an approximate representation of local streets, most of which are not included in the travel model.

- **Interstate** – Freeways are divided, restricted access facilities with no direct land access and no at-grade crossings or intersections. Freeways are intended to provide the highest degree of mobility serving higher traffic volumes and longer-length trips.
- **Expressway** – Expressway facilities are sometimes classified as divided principal arterials but include many features common to freeways. Expressways use a higher level of access control than other arterials and may include grade-separated intersections. Expressways have higher speed limits than other principal arterials (e.g., 55 or 65 MPH), provide little or no direct access to local businesses, may have frontage roads or access roads, and limit signal spacing to at least ½ mile.
- **Principal Arterial** – Principal arterials permit traffic flow through and within urban areas and between major destinations. These are important to the transportation system since they provide local land access by connecting major traffic generators, such as central business districts and universities, to other major activity centers. Principal arterials carry a high proportion of the total urban travel on a minimum of roadway mileage. They typically receive priority in traffic signal systems (i.e., have a high level of coordination and receive longer green times than other functional classes). Divided principal arterials have turn bays at intersections, include medians or center turn lanes, and sometimes contain grade separations and other higher-type design features. State and US highways are typically designated as principal arterials unless they are classified as freeways.
- **Minor Arterial** – Minor arterials collect and distribute traffic from principal arterials and freeways to streets of lower classification and, in some cases, allow traffic to directly access destinations. They serve secondary traffic generators, such as community business centers, neighborhood shopping centers, multifamily residential areas, and traffic between neighborhoods. Access to land use activities is generally permitted, but should be consolidated, shared, or limited to larger-scale users. Minor arterials generally have slower speed limits than principal arterials, may or may not have medians and center turn lanes, and receive lower signal priority than other functional classes (i.e., are only coordinated to the extent that principal arterials are not disrupted and receive shorter green times than principal arterials).
- **Collector**– Collectors provide for land access and traffic circulation within and between residential neighborhoods and commercial and industrial areas. They distribute traffic movements from these areas to arterial streets. Except in rural areas, collectors do not typically accommodate long through trips and are not continuous for long distances. The cross-section of a collector street may vary widely depending on the scale and density of adjacent land uses and the character of the local area. Left turn lanes sometimes occur on collector streets adjacent to non-residential development. Collector streets should generally be limited to two lanes, but sometimes have 4-lane sections.
- **Frontage Road** – Frontage roads are identified as facilities similar to minor arterials or collectors but serve a specific purpose in providing local access adjacent to a freeway or expressway.
- **Local** – Local streets directly serve residential neighborhoods and some commercial uses. Only a small number of local streets are included in the model in order to properly represent connectivity in and between neighborhoods. Most local streets are instead represented by centroid connectors.
- **Ramp** – Ramps provide connections between freeways and other non-freeway roadway facilities. On freeway to non-freeway ramps, traffic usually accelerates or decelerates to or from a stop. Therefore, the free-flow speed on freeway to arterial ramps is often coded as much slower than the ramp speed limit.

- **Transit Only** – Transit only links represent right of ways that are exclusive for transit use. These are particularly important when including premium modes such as Bus Rapid Transit (BRT) or Light Rapid Transit (LRT) routes in the transit system. General traffic is prohibited from using these links, and speeds can be adjusted in the speed lookup table to represent transit operating speeds.
- **Bicycle Only** – Bicycle only links can be used to represent bicycle facilities that are not associated with a roadway. These are most useful when bicycle connections make it possible to complete a trip on a bicycle using a shorter route than would be possible using roadway links.

3.2.2 Bicycle Facility Type

Bicycle facility type defines the bicycle facilities available on the roadway network. Bicycle pathbuilding prioritizes higher level bicycle facilities (i.e., facilities with a lower Bike FT value) and excludes facilities where bicycles are prohibited. Bicycle facility types are defined by the network variable BikeFT and as defined in **Table 3.4**. Bicycle facilities include roadways and other non-motorized facilities such as bike paths. Bike paths not directly adjacent to a roadway can be coded with a roadway functional class value of 61.

Table 3.4 Bicycle Facility Type

BikeFT	Bicycle Facility Type
1	Bike trails / mixed use paths
2	Bike lanes
3	Bike routes / bikeable shoulders
4	No specific treatment, but bikes allowed
-1	Bikes prohibited

3.2.3 Area Type

Area type is an attribute assigned to each TAZ and roadway and is based on the activity level and/or character of the zone. Terminal times, free-flow speeds, roadway capacity, and volume-delay characteristics are dependent on area type. Area type is first defined at the TAZ level based on socioeconomic characteristics and then transferred to the roadway network

Area type values are maintained in the TAZ dataset for each model year. Area type is then transferred from the TAZ layer to the roadway network layer using an automated process. This process assigns links along an area type boundary to the denser area type, and also ensures that consistent area type values are assigned to links within interchanges. This automated process uses buffering to prevent links from alternating between area types along borders, removing the need to manually review results of the zone to link area type transfer procedure.

Both employment and household density was calculated for each TAZ using a buffer of 0.75 miles. These density variables are calculated for each TAZ as employment per acre and households per acre for all zones that are at least partially within 0.75 miles of a TAZ centroid.

Area type for each TAZ is then calculated based on activity densities as defined in **Table 3.5**. There are five area types: Central Business District (CBD), CBD Fringe, Urban, Suburban and Rural. The CBD area type is not based on activity density, but rather on the historical definition of the CBD boundary. Results of the area type model were reviewed and parameters adjusted until manual smoothing of area type model results became unnecessary.

Table 3.5 Area Type Ranges

Area Type	Area Type Name	Lower Limit Household Density	Lower Limit Employment Density
1	CBD	n/a (fixed)	n/a (fixed)
2	CBD Fringe	n/a	9
3	Urban	4	3.5
4	Suburban	0.3	1.2
5	Rural	n/a	n/a

Note: Each zone is assigned the densest area type for which it exceeds **either** the household or employment density specified.

3.2.4 Link Speeds

Network speeds are used to calculate travel times that are used in the trip distribution model to distribute trips throughout the model area and in the trip assignment model to route traffic on the roadway network.

Link free-flow speeds represent average travel time, including intersection delay, needed to traverse the distance of a link with little or no traffic (i.e., no congestion effects). These speeds are generally similar to the posted speed and are calculated based on functional class and area type. Free-flow speeds are typically lower than the speed limit to account for intersection delay on arterials, collectors, and ramps but may be higher than the posted speed on freeways.

During this model update, free-flow speeds for certain functional class/area type destinations were revised. This was done based on a review of model volumes and traffic counts in each category, followed by review of example links using aerial photography and Google Street View. The resulting free-flow speeds are tabulated in **Table 3.6**.

Table 3.6 Free-flow Speed Lookup Table

	Functional Class	CBD (1)	CBD Fringe (2)	Urban (3)	Suburban (4)	Rural (5)
0	Centroid Connector	20	20	20	20	20
1	Freeway	65	65	70	70	70
2	Expressway	50	50	50	45	50
3	Principal Arterial	15	25	40	45	50
4	Minor Arterial	15	20	30	37	40
5	Collector	15	20	27	33	35
7	Local	15	20	22	23	24
20	Ramp	15	20	30	30	30
51	Transit Only	n/a	n/a	n/a	n/a	n/a
61	Non-Motorized	n/a	n/a	n/a	n/a	n/a

Source: Destino Travel Model, reviewed and updated for use in the RMS Model.

3.2.5 Link Capacities

Capacity constrained traffic assignment requires roadway capacity values on each network link. The model uses link capacity to measure congestion and to determine route diversion due to slower travel speeds associated with increasing congestion. This is accomplished through volume-delay equations that are further documented in **Section 10.2.3**.

In the model, per-lane capacity values are retrieved from a lookup table based on the functional class and area type of each link in the roadway network, shown in **Table 3.7**. This approach eliminates opportunities for error in defining capacities at the link level and enforces consistent application of capacity values. These hourly lane capacities are used in combination with the number of lane information present on the network to define hourly directional capacity.

Table 3.7 Hourly Lane Capacity Lookup Table

	Functional Class	CBD (1)	CBD Fringe (2)	Urban (3)	Suburban (4)	Rural (5)
0	Centroid Connector	10,000	10,000	10,000	10,000	10,000
1	Freeway	2,000	2,000	2,000	2,000	2,000
2	Expressway	1,750	1,750	1,700	1,700	1,700
3	Principal Arterial	860	840	840	840	800
4	Minor Arterial	800	800	800	780	770
5	Collector	750	750	750	720	720
7	Local	550	550	550	500	500
20	Ramp	1,550	1,550	1,550	1,550	1,550
51	Transit Link	n/a	n/a	n/a	n/a	n/a
61	Non-Motorized	n/a	n/a	n/a	n/a	n/a

Source: Destino Travel Model, reviewed and retained for use in the RMS Model.

Period Capacities

Although hourly capacity is useful for most applications, the traffic assignment model requires separate time period capacities. Both mid-day and night-time capacity are calculated by multiplying the number of hours in the time period by the hourly capacity. The mid-day capacity represents 5.5 hours, while the off-peak capacity represents 11.5 hours. For peak periods, higher traffic volumes in the peak hour must be considered. Peak period capacity can be calculated using the equation below.

$$PeriodCapacity = \frac{HourlyCapacity}{PeakHourTrafficShare}$$

The survey reveals that 40% of the 3-hour AM period traffic occurs during the peak hour. Consequently, the AM peak period capacity is 2.5 times the hourly lane capacity. Similarly, the survey reveals that 28% of the 4-hour PM period traffic occurs during the peak hour. Consequently, the PM peak period capacity is 3.57 times the hourly lane capacity.

3.2.6 Toll and HOV Coding

Tolling is indicated on the highway network using a toll value which identifies a specific set of per-mile toll rates and/or flat cost toll values at specified locations. In typical application, tolls are specified as either per-mile (e.g., \$0.05/mile for long segments), or flat rate (e.g., a \$2.50 toll at a toll plaza or access link). Fields present in the toll table are defined in **Table 3.8**. However, since the RMS Model does not feature any toll facilities in the base year, toll functionality is only present in forecast year networks. Toll cost data for all years are entered in 2017 dollars for consistency with other costs in the travel model.

Table 3.8 Toll Table Fields

Field Name	Table Header
Toll_SOV_PK_17	Tolls to be paid by single occupancy vehicles in the peak periods
Toll_HOV2_PK_17	Tolls to be paid by shared ride 2 vehicles in the peak periods
Toll_HOV3_PK_17	Tolls to be paid by shared ride 3+ vehicles in the peak periods
Toll_SOV_OP_17	Tolls to be paid by single occupancy vehicles in the off-peak periods
Toll_HOV2_OP_17	Tolls to be paid by shared ride 2 vehicles in the off-peak periods
Toll_HOV3_OP_17	Tolls to be paid by shared ride 3+ vehicles in the off-peak periods
Toll_LTK_PK_17	Tolls to be paid by light truck vehicles in the peak periods
Toll_MTK_PK_17	Tolls to be paid by medium truck vehicles in the peak periods
Toll_HTK_PK_17	Tolls to be paid by heavy truck vehicles in the peak periods
Toll_LTK_OP_17	Tolls to be paid by light truck vehicles in the off-peak periods
Toll_MTK_OP_17	Tolls to be paid by medium truck vehicles in the off-peak periods
Toll_HTK_OP_17	Tolls to be paid by heavy truck vehicles in the off-peak periods

The HOV field indicates whether the link is an HOV lane, and assigns restrictions to certain vehicle classes prohibiting them from using the HOV lanes. An HOV value of 2 (indicating a 2+ HOV lane) prohibits trucks and SOVs, while an HOV value of 3 (indicating a 3+ HOV lane) prohibits SOVs, SR2 vehicles, and trucks.

3.2.7 Rutable Network

Many functions in TransCAD require the creation of a rutable network file, identified by a “.net” extension. For the RMS Model, the path building/skimming and traffic assignment procedures require a rutable network. A rutable network is also required when editing transit route systems. Rutable network files store link length, turn penalty information, and travel time information for each link. An appropriate rutable network file is created during automated network initialization.

Specific turn prohibitions are initially stored in a separate file referenced when creating the rutable network. The RMS model only uses turn penalties to represent localized delays associated with queuing at a border crossing. This queueing related turn penalties are removed from forecast year models to reflect roadway improvements that address the issue.

The rutable network file contains information about centroid connectors to prevent pathbuilder and traffic assignment algorithms from routing trips through centroids. The model automatically creates a selection of centroid nodes and identifies nodes as centroids in the rutable network file.

4.0 Transit Network

The travel model uses transit networks to build the shortest paths between each zone pair for transit trips. Shortest paths are determined by minimizing a weighted combination of costs, times, and penalties encountered during a trip. Variables representing the resulting shortest paths are used as inputs to the mode choice model. The RMS Model uses information stored on the roadway network layer, including congested travel times, and a TransCAD route system to represent the transit networks. For transit pathbuilding, the RMS Model uses the “Pathfinder” method provided by the TransCAD software.

4.1 Transit / Roadway Linkage

Transit networks in TransCAD are made up of two separate but connected parts: the transit route system and the transit roadway network. The transit route system includes two layers, routes and stops. The transit roadway network includes link and node layers and is a copy of the roadway network used for vehicle modeling. Information from these four layers is combined as shown in **Figure 4.1** to allow representation of walk and in-vehicle components of a transit trip. Drive access to transit can be represented in a similar manner, with drive access replacing the walk access indicated in **Figure 4.1**. Because these layers are connected, information on the roadway network, such as link travel times and centroid data, is available to the route system. This connection requires the roadway and transit networks to be maintained in a manner that prevents them from becoming inconsistent with each other.

Figure 4.1 Connections between the Route System and Transit Line Layer

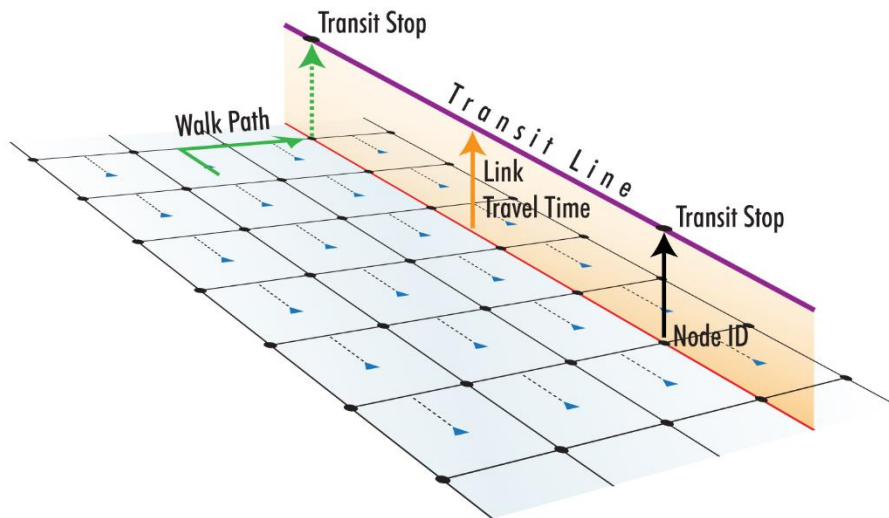

4.2 Transit Route System

Transit routes and stops are represented within the TransCAD route system. Contents of the route system are based on schedule data from Sun Metro and El Paso County.

4.2.1 Route System Attributes

Each route is represented as a unique feature in the route system layer. Like the line layer, the route system layer includes attributes for each feature. These attributes contain route-specific information such as route name and headway. Notably absent from the list of route system attributes is travel time. The TransCAD model computes stop-to-stop travel time using attributes on the underlying link layer rather than attributes stored directly on the route system. A list of route attributes is included as **Table 4.1**.

Table 4.1 Route Attributes

Field Name	Description	Comments
Route_ID	TransCAD Unique ID	Maintained automatically by TransCAD
Route_Name	Short descriptive route name	Unique route name used for route identification
Mode	Transit Mode ID	See Table 4.2 .
Dwell	Stop dwell time	Stop dwell time has been set to 0.25 minutes for all routes
PK_HDWY	Peak route headway	Peak and off-peak headways from transit operator.
OP_HDWY	Off-peak route headway	
Fare	Indicates the fare used in pathbuilding and mode choice	This value represents the average fare paid by transit riders (in 2017 dollars)

Transit Modes

The RMS Model features four primary types of transit service: local bus, circulator, express bus, and premium transit. Premium transit can represent bus rapid transit (BRT) service or can be used to represent proposed rail service. Each mode is coded with a separate Mode value, allowing different speed, in-vehicle travel time weights, and other attributes to be specified at the mode level. Mode values available in the RMS Model are specified in **Table 4.2**.

Transit routes are coded directly on roadway links and may also use local streets or transit facilities such as BRT lanes or rail that are not included in the roadway model. These transit-only streets or lanes are coded using the *Transit Link* functional class, 51. Transit links are not available for use by vehicles, even though they may represent local streets.

Table 4.2 Transit Network Mode Values

Mode ID	Mode Description
1	Local Bus
2	Circulator
3	Express Bus
4	Premium Transit (e.g. BRT)

Transit Stops

The transit route system includes transit stop locations coded at all locations where transit access may be possible. For local bus routes, transit stops were not coded based on actual stop locations, rather they are designed to represent good access to all routes. For other types of service, such as limited stop, express, or BRT, stops can be coded based on actual or proposed stop locations.

Routes can only be boarded or alighted at stops. To facilitate a connection to the transit line layer, all transit stops must be coded to coincide with a distinct node on the input roadway network. Furthermore, only one stop can be coded per direction, per route, per node. At stations and transfer points, multiple stops are coded on the same node, but each is associated with a different route. Attributes maintained on the route stop layer are listed in **Table 4.3**.

The TransCAD route system structure does not require transit stops to be located at nodes on the transit line layer. However, when the transit network processing model step is performed, each transit stop is matched to the closest node on the transit line layer. If the route system contains stops that cannot be matched to nodes, the model will fail to run.

Table 4.3 Route Stop Attributes

Field Name	Description	Comments
ID	TransCAD Unique ID	These fields are all maintained automatically by TransCAD and are read-only.
Longitude	Longitude coordinate of the stop	
Latitude	Latitude coordinate of the stop	
Route_ID	ID of the route associated with the stop	
Pass_Count	Used to associate a stop with one of multiple times a route passes a particular node.	
Milepost	Distance from the route starting point	
STOP_ID	Unique stop ID (identical to ID)	
NodeID	Identifies the ID of the node on the network layer that matches the route stop	This field is filled automatically when the model is run.

4.2.2 Base Year Transit Routes

Figure 4.2 shows the base year 2017 transit routes.

Figure 4.2 El Paso Base Year Transit Routes

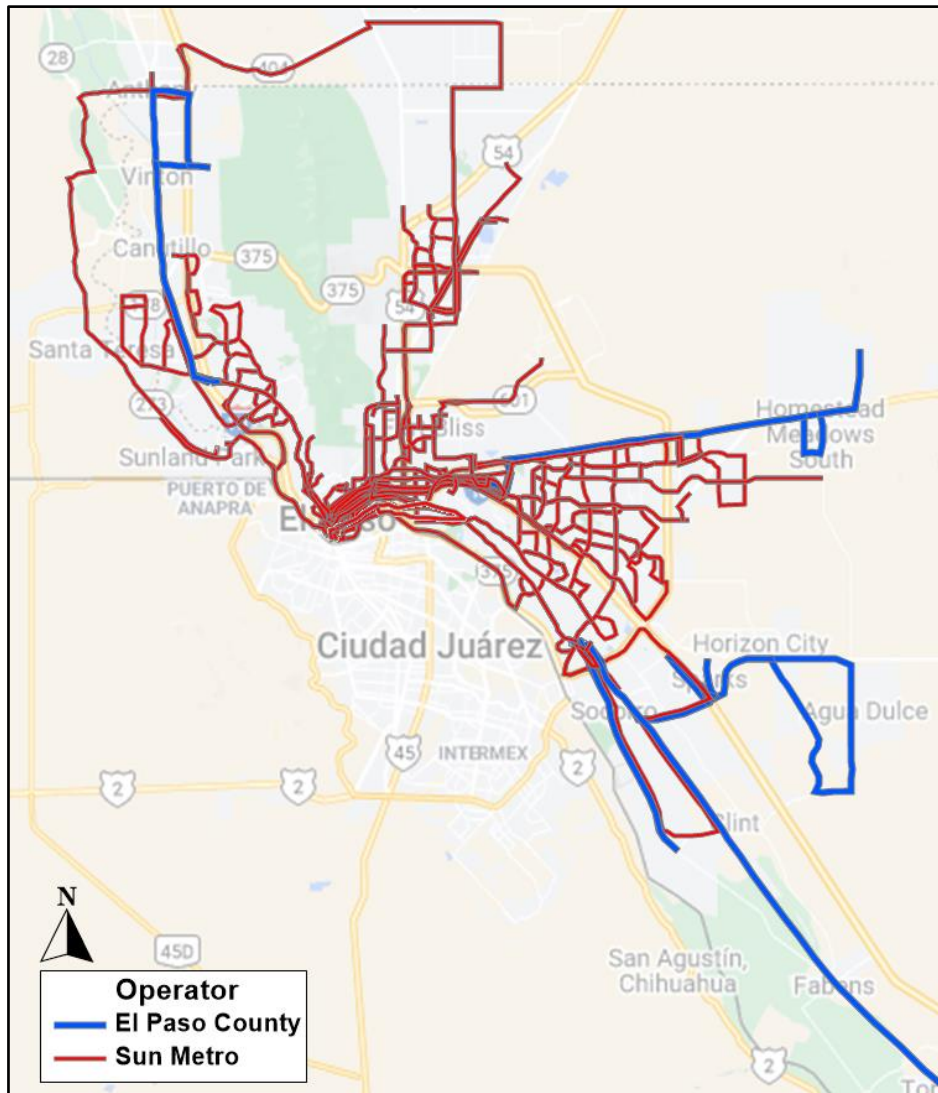

4.3 Transit Roadway Network

Some transit variables are maintained on the output copy of the roadway network rather than the route system, allowing for interaction between the roadway and transit networks. Transit travel time is calculated as a function of vehicle travel time on each link. The transit line layer also provides a connection between TAZ centroids and route stops. This connection is provided in the form of centroids, roadway links, and non-motorized links in the roadway network.

4.3.1 Transit Travel Time

Transit travel time is computed by applying area type and functional class specific delays shown in **Appendix B** to congested travel time. These adjustments represent the observed difference between transit route times and congested network times. Transit times are calculated according to the equation below.

$$TransitTime = DelayFactor \cdot LinkLength + CongestedTime$$

During roadway and transit network processing, the fields listed in **Table 4.4** are populated with data required for transit and non-motorized modeling. When running speed feedback (discussed in detail in Section 10.3), the model calculates transit speeds based on the congested speeds resulting from speed feedback.

Table 4.4 Key fields in Transit Line Layer

Field Name	Description	Comments
TrnTimePKL_[AB/BA]	Peak period transit time – local bus and circulators	
TrnTimePKE_[AB/BA]	Peak period transit time – express bus	
TrnTimePKS_[AB/BA]	Peak period transit time – premium transit	Based on the off-peak link time resulting from speed feedback
TrnTimeOPL_[AB/BA]	Off-peak period transit time – local bus and circulators	
TrnTimeOPE_[AB/BA]	Off-peak period transit time – express bus	
TrnTimeOPS_[AB/BA]	Off-peak period transit time – premium transit	
WalkTime_[AB/BA]	Walk travel time	Used for transit walk access
WalkMode	Flag identifying the mode value for walk links	Must match the walk model in the MODE table.

4.3.2 Walk Access and Egress

The transit line layer also represents the connection between TAZ centroids and transit route stops. Except for park-n-ride trips, all transit trips must start and end on foot¹. Walk access and egress occurs using the roadway network, including centroid connectors and most roadways. Walk access cannot occur on freeway and expressway links.

4.3.3 Walk Access/Egress Adjustment

Walk access and egress times generated in the pathbuilding process represent the walk time to/from the zone centroid to the transit stop used by the trip maker. Consistent network coding practices ensure this value is reasonable, and more importantly consistent, for all zones with access to transit. During model application, walk times are adjusted to represent varying walk access and egress times for different portions of each TAZ.

Walk access and egress times are segmented into short (less than ¼ mile), medium (less than ¾ mile), and long (over ¾ mile) distance from transit. The 24-minute walk time used for transit trips in the long market segment results in a very small number of walk access to transit from portions of zones further than ¾ of a mile from a transit stop. The model computes access and egress times for each walk distance market segment included in a zone. The rules outlined below are used to compute walk access and egress times by market segment.

- If a zone falls completely within one market segment, walk times are read directly from the network.

¹ Bicycle access and egress to transit is not modeled explicitly but is instead modeled as walk access and egress.

- If a zone falls in two or more market segments, the following procedure is used:
 - The minimum walk times specified for each market segment in **Table 4.5** are used; and
 - For each zone pair, if the stop on the first route is not the closest stop to the zone centroid, the distance between the stop and the closest stop is added to the minimum walk time. This prevents the model from assuming an unreasonably short walk time in cases where the route used for a path does not make use of the closest stop to a zone.

Table 4.5 Minimum Walk Access/Egress Times by Market Segment

Market	Minimum Walk Time
Short	3 minutes
Medium	12 minutes
Long	24 minutes

Transit market segmentation related to walk access adjustments is described further in Section 9.2.1.

4.3.4 Drive Access

The transit network connects TAZs to route stops to represent transit trips made using a park-n-ride. Drive access connectivity is only provided in the direction from TAZs to route stops. The model allows trips from a production zone to a park-n-ride, but not from a park-n-ride to an attraction zone. This prevents drive egress trips due to the mode choice and transit modeling convention that transit pathbuilding and assignment is performed in *Production/Attraction* format rather than *Origin/Destination* format. By following this convention, it is possible to limit drive access to transit to the production (or home) end of each trip. Because transit riders do not typically have access to a vehicle at the attraction (or non-home) end of a trip, transit egress is limited to the walk mode.

Drive access to transit is provided using centroid connectors and roadway links. Zone to park-n-ride travel times are computed using peak and off-peak travel times on the roadway network. Drive access is only provided to specially designated park-n-ride nodes, identified by the input park and ride table.

4.4 Transit Pathbuilding

Transit networks are built in the TransCAD software for use with the Pathfinder transit shortest path method. The Pathfinder method is unique to the TransCAD software and builds paths using a weighted generalized cost approach. Each component of a transit trip is converted into a common unit, allowing application of different weights to each trip component. Pathfinder weights have been set for consistency with coefficients in the mode choice model.

The Pathfinder evaluates possible transit paths between each zone pair and identifies the path with the lowest generalized cost. Path components considered by the Pathbuilder setup in the RMS Model are listed along with pathbuilding weights in **Table 4.6**.

Table 4.6 Transit Pathbuilding Weights

Variable	Description	Weight
Walk Access Time	Time spent walking from the production TAZ centroid to the transit stop (for walk access trips only)	2.5
Drive Access Time	Time spent driving from the production TAZ centroid to a park-n-ride (for drive access trips only)	1
Drive Access Cost	Auto operating cost associated with drive access (for drive access trips only)	1
Initial Wait Time	Time spent waiting for the first bus to arrive, computed as one-half of the route headway.	2.5
In-Vehicle Travel Time	Time spent riding or waiting in a transit vehicle	1
Transfer Wait Time	Time spent walking between stops for a transfer (if applicable)	2.5
Transfer Walk Time	Time spent walking between stops for a transfer (if applicable)	2.5
Transfer Penalty Time	Additional transfer penalty (calibration parameter)	2.5
Egress Walk Time	Time spent walking from the transit stop to the attraction TAZ centroid	2.5
Fare	Transit fare paid for the trip	1

Note: Travel time variables are converted for consistency with cost variables using the value of time documented in the mode choice model specification.

5.0 External Travel

Separate from internal-internal (II) trips that occur entirely within the modeling area, the model includes external travel from outside of the region. Trips with one end inside the modeling area and the other outside of the area are called Internal-External and External-Internal (IE/EI) trips. Through trips, or External-External (EE) trips, are those which pass through the modeling area without stopping (or with only short convenience stops). External travel is modeled at the external stations where roadways cross the model boundary.

5.1 External Station Locations

The 21 external stations used when running the model for the MPO only are shown in **Figure 5.1**.

Figure 5.1 El Paso External Station Locations

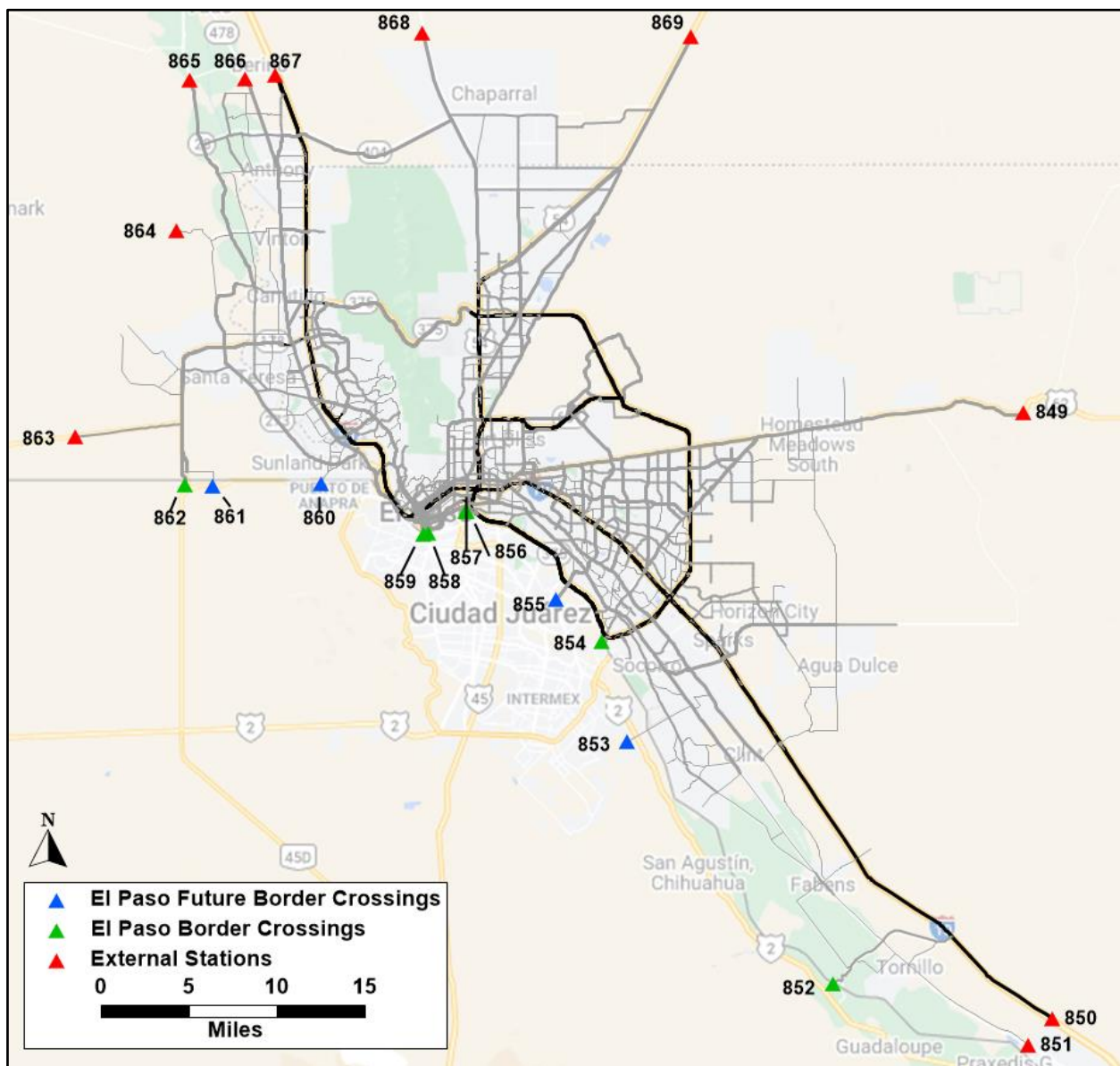

5.2 Base Year External Travel

5.2.1 External Station Volumes

The first step in estimating external travel for the model is to determine the average weekday traffic at each location in the base year. This process begins with traffic count data for all external stations. Counts represent an average weekday in March, April, September, October, and November (i.e. an “average weekday when school is in session”).

The model also requires information about the split between autos and trucks, as well as the split between EE and IE/EI trips at each external station. Vehicle class shares were determined by vehicle classification counts at external stations where available. In cases where vehicle classification counts were not available, nearby counts or assumptions based on external station facility type were used. The splits between EE and IE/EI trips were determined based on a combination of assumptions in the Destino Model and a review of major routes through the region. External stations are listed in **Table 5.1** along with total volumes, truck shares, and EE trip shares.

Table 5.1 External Travel Assumptions

ID	Name	Volume	% Truck	% EE
849	US 62 East	2,500	30%	18%
850	I-10 East	22,970	13%	22%
851	SH 20 / Alameda Ave. East	590	22%	0%
852	Tornillo-Guadalupe Border Crossing	1,530	0%	5%
853	Proposed Border Crossing	0	0%	0%
854	Ysleta Border Crossing	24,310	13%	10%
855	Proposed Border Crossing	0	0%	0%
856	Bridge of the Americas Truck	1,770	100%	46%
857	Bridge of the Americas PSS	35,660	0%	5%
858	Stanton Street Border Crossing	7,660	0%	5%
859	El Paso Street Border Crossing	5,570	0%	5%
860	Proposed Border Crossing	0	0%	0%
861	Santa Teresa Border Crossing (not used)	0	0%	0%
862	Santa Teresa Border Crossing	4,360	20%	8%
863	SH-9 West	640	2%	5%
864	CR A-020 West	200	20%	0%
865	SH-28 Lou Henson Hwy. North	1,010	12%	0%
866	SH-478 North	3,010	14%	0%
867	I-10 North	20,960	36%	29%
868	SH-213 Martin Luther King Jr Blvd. North	1,550	5%	0%
869	US 54 North	4,140	10%	9%

Source: Cambridge Systematics analysis of traffic count data combined with Destino Model assumptions.

Due to limited available data, the share of trucks falling into the light commercial vehicle, medium truck (FHWA vehicle classes 6-7) and heavy truck (FHWA vehicle classes 8-13) classifications are assumed generally for external stations bordering Mexico and for all other external stations. At the border, light commercial vehicles must use commercial vehicle lanes and therefore are included in the commercial vehicle totals. At domestic external stations, light commercial vehicles are not distinguishable from personal vehicles since trucks are defined by vehicle class. These assumptions, based on analysis of vehicle class counts available at some but not all border crossings, are shown in **Table 5.2**. Truck type shares can be updated if additional data is obtained.

Table 5.2 External Trip Truck Classification Shares

External Station Type	Light Commercial	Medium Trucks	Heavy Trucks
International	5%	30%	65%
Domestic	n/a	35%	65%

Note: 5% of light duty vehicles and busses (FHWA vehicle classes 1-5) are assumed to be commercial vehicles at domestic external stations.

5.2.2 Internal-External and External-Internal Trips

Internal trip ends for IE/EI are represented by trip productions at external stations and by trip attractions at internal TAZs. Internal trip-ends are generated as the EXTINT trip purpose and IE/EI trips are distributed using friction factors defined for the NHB trip purposes. More information on generation and distribution of external trips is included in the relevant sections that follow.

5.2.3 External-External Trips

The external to external trip process matches through trip-ends from each external station with through trip-ends at another external station. The model applies an iterative proportional fitting process that estimates an EE trip matrix based on an input seed. The resulting through trip matrix is included in the vehicle trip tables assigned to the highway network. The external trip seed matrix, shown in **Table 5.3**, was developed based on a review of major routes through the region along with traffic count volumes. Zero values in the seed table assume a particular movement does not happen. This includes trips between different border crossings, or trips that are unlikely to occur due to geographic placement of routes (e.g., trips entering and exiting on the north model boundary). Zone pairs with potential interaction are represented by a 1 and zone pairs with the most common interaction (i.e. trips entering and exiting on I-10) are represented by a seed value of 2.

Table 5.3 External Trip Seed Matrix

Station Name	ID	849	850	852	854	856	857	858	859	862	867	869
US 62 East	849	0	0	1	1	1	1	1	1	1	1	1
I-10 East	850	0	0	1	1	1	1	1	1	1	2	1
Tornillo-Guadalupe Border Crossing	852	1	1	0	0	0	0	0	0	0	1	1
Ysleta Border Crossing	854	1	1	0	0	0	0	0	0	0	1	1
Bridge of the Americas Truck	856	1	1	0	0	0	0	0	0	0	1	1
Bridge of the Americas PSS	857	1	1	0	0	0	0	0	0	0	1	1
Stanton Street Border Crossing	858	1	1	0	0	0	0	0	0	0	1	1
El Paso Street Border Crossing	859	1	1	0	0	0	0	0	0	0	1	1
Santa Teresa Border Crossing	862	1	1	0	0	0	0	0	0	0	1	1
I-10 North	867	1	2	1	1	1	1	1	1	1	0	0
US 54 North	869	1	1	1	1	1	1	1	1	1	0	0

Note: External stations with zero through traffic share are not shown in this table.

5.2.4 External Station Forecasting

Forecast year model runs require traffic volume forecasts at each external station. These forecasts can be developed using a number of available procedures, listed below.

- Direct scaling of all external station volumes based on population growth within the modeling area.
- Growth of external station values individually based on analysis of the Texas Statewide Model.
- Growth of external station values using trend analysis from historical traffic count volumes.

The forecast model uses a combination of historical trend analysis (for domestic external stations) and growth based on regional population and employment growth (for border crossings).

6.0 Trip Generation

Trip generation is the first phase of the traditional four-step travel demand modeling process. It identifies trip ends (productions and attractions) that correspond to places where activities occur, represented by socioeconomic data (households and employment). Trip generation estimates productions and attractions by trip purpose for each TAZ, then balances trips at the regional level so total productions and attractions are equal. The resulting productions and attractions by trip purpose and TAZ are subsequently used by the Trip Distribution model to estimate zone-to-zone travel patterns.

The primary data source for estimating trip productions and attractions is the El Paso MPO modeling area is the 2010-2011 Household Travel Survey. Since the survey is household-based, it provides excellent information with regard to household trip-making. The survey is especially well suited for estimating trip production rates. The survey also provides good information for estimating trip attraction rates based on participant employment type and attraction place information. Detailed analysis of the household survey was conducted in development of the Destino Model. Since a new household travel survey is not available, trip rates from the Destino model were carried forward with only minor adjustments made during model calibration and validation.

The trip generation model uses TripCAL6, a new trip generation model developed by the Texas Transportation Institute (TTI) for the Texas Department of Transportation (TxDOT). This version of TripCAL replicates functionality available in the previous version, but is run entirely from within the TransCAD software. An overview of the model and its operation can be found in the TexPACK Model Documentation, Version 2.6.

6.1 Socioeconomic Input Data

Trip generation requires household and employment data at the TAZ level. This information, called socioeconomic data (SED) or demographic data, has been developed for the base year using Census and American Community Survey (ACS) data for households and population along with InfoUSA employment data (at the NAICS code level). Forecast year SED was developed through use of a Delphi process at a subarea level followed by a technical process to allocate growth to individual TAZs and forecast year socioeconomic and demographic data. Regional household and population totals were developed based on guidance from the Texas Demographic Center (TDC). Further information on the socioeconomic data development process is documented separately².

6.1.1 Household and Population Data

Household and population input data is provided to the model at a TAZ level, with the following variables input for each TAZ:

- Total number of Households.
- Population in Households

² El Paso Travel Demand Model Demographic Development, March 2021

- Group Quarters Population
- Total Population (population in households plus group quarters population).
- Average household size (population in households divided by number of households)
- Median household income in 2017 dollars.
- Average workers per household.

In addition the model requires a tri-variate regional joint distribution of households by income, size, and number of workers. Joint distributions are generated at the TAZ level based on the input SED using household disaggregation procedures included in TripCAL 6.

The tabulated household resulting from the household disaggregation model includes the following categories:

- Household sizes are categorized into 1-person households through 5+ person households.
- Number of resident workers is categorized into 0-worker households through 2+ worker households.
- Income groups are classified into the five categories shown in **Table 6.1**.

Table 6.1 Income Group Definitions

Income Group	Income Range (2012 dollars)	Income Range (2017 dollars)
Low	\$14,999 and lower	\$16,861 and lower
Medium-low	\$15,000 to \$24,999	\$16,862 to \$28,102
Medium	\$25,000 to \$39,999	\$28,103 to \$44,963
Medium-high	\$40,000 to \$69,999	\$44,964 to \$78,687
High	\$70,000 and higher	\$78,688 and higher

Source: Destino Travel Model, reviewed and adjusted for use in the RMS Model.

6.1.2 Employment and Employment Data

The trip generation model uses employment data at the TAZ level based on the categories shown in **Table 6.2**. Employment types are defined based on North American Industrial Classification System (NAICS) codes listed in this table. Enrollment data is required for K-12 and college/university categories. Detailed descriptions of the NAICS codes can be found in **Appendix C**.

Table 6.2 Employment Type Categories

Employment Type	NAICS Codes
Basic	11, 21- 23, 31-33, 42, 48-49, 5111, 5112, 512, 5151, 5152, 5174
Retail	44-45, 491, 51213, 71, 722
Service	5171, 5179, 518, 519, 52-56, 6114, 6115, 6116, 6117, 62, 81, 92, 721
Education	6111, 6112, 6116

Source: RMS Model Demographic Data Development Report

6.1.3 Socio-Economic Data Summary

SED for the base (2017), interim, and forecast (2050) years are shown in **Table 6.3**.

Table 6.3 Socio-Economic Data Summary

	2017	2022	2027	2030	2032	2040	2050
Total Households	285,417	310,688	330,479	341,332	348,630	376,374	414,836
Household Population	881,700	935,234	968,646	985,664	995,974	1,036,930	1,106,259
Group Quarters Population	16,349	17,219	17,219	17,219	17,219	17,219	17,219
Total Population	898,049	952,453	985,865	1,002,883	1,013,193	1,054,149	1,123,478
Basic Employment	65,016	69,262	70,243	70,402	70,923	73,369	79,038
Retail Employment	76,684	82,292	92,425	101,692	107,398	128,395	152,807
Service Employment	130,150	150,869	166,365	176,006	182,375	206,000	236,414
Education Employment	39,823	40,460	40,667	43,024	44,580	50,791	58,661
School Enrollment (K-12)	194,664	200,644	201,745	216,559	226,178	263,140	310,017
College/University Enrollment	82,681	82,681	82,681	82,681	82,681	85,181	87,681

Source: Base, Interim, and Forecast Year Socio-Economic Data

6.2 Trip Purposes

Trip purpose is used in travel models to categorize various types of trips with similar characteristics, such as trip rates, trip length, and auto occupancy. A separate set of trip generation rates has been developed for each individual trip purpose. The trip purposes in the RMS Model are listed below.

- 1. Home-Based Work (HBW):** Commute trips between home and work.
- 2. Home-Based Non-Work Education 1 (HNWE1):** Trips between home and K-12 school locations for students in these schools.
- 3. Home-Based Non-Work Education 2 (HNWE2):** Trips between home and colleges/universities by people not employed by these institutions.

4. **Home-Based Non-Work Retail (HNWR):** Trips between home and retail locations for the purpose of shopping.
5. **Home-Based Non-Work Other (HNWO):** All other trips that have one end at home.
6. **Non-Home-Based Work (NHBW):** Trips starting or ending at work, but without an end at home; represented by non-home based (NHB) trips in Trip Generation and Trip Distribution.
7. **Non-Home-Based Other (NHBO):** Trips with neither an end at home nor a work-related purpose; represented by non-home based (NHB) trips in Trip Generation and Trip Distribution.
8. **External Internal (EXTINT or IE/EI):** All trips that have one end outside the modeling area.
9. **Light Trucks (LT):** Light truck trips (Commercial vehicles under FHWA Vehicle classes 2-5)
10. **Medium Trucks (MT):** Medium-heavy truck trips (FHWA Vehicle classes 6-7)
11. **Heavy Trucks (HT):** Heavy truck trips (FHWA Vehicle classes 8-13)

The two non-home-based (NHB) trip purposes are generated and distributed as a single NHB purpose. Prior to mode choice, NHB trips are separated into NHBW (19.4%) and NHBO (80.6%) purposes. Conversion from NHB to NHBW and NHBO trips is based on analysis of household survey data, with the approach retained from the Destino model.

6.3 Production Rates

Production rates for the RMS Model are based on a detailed analysis of household survey data that was conducted during development of the Destino Model. This analysis produced trip production rates that vary by household size, income, and number of workers. The Destino Model development process included a calibration procedure in which trip rates were applied and adjusted by market segment in order to match expanded household survey data. These trip rates were increased by 10% and then 5% as part of the Destino model development.

In RMS Model Development, additional trip rate increases were applied. This was done after ensuring a reasonable match to observed trip length frequency distributions (see Section 7.2), mode shares (see Sections 9.1 and 11.3), and that the model included sufficient VMT from external traffic. The following additional factors were applied.

- Home-based trip rates in the highest two income groups were increased by 5% after observing that the model was under-predicting traffic in higher income neighborhoods. This adjustment improved validation in these areas and overall.
- Non-home-based trip rates were increased by 12% after review of aggregated LBS data by trip purpose. This dataset, which includes travel by both residents of the modeling area and visitors with households outside of the modeling area, showed that the model was under-representing non-home-based trips as a share of all trips prior to this adjustment.

The resulting trip rates produce a regional average of 8.3 home-based person trips per household and 5.3 home-based vehicle-trips per household. This value is within the range of vehicle trip rates for single-family and multi-family dwelling units published by the Institute of Transportation Engineers (ITE)³.

As shown in **Table 6.4** through **Table 6.9**, trip rates generally increase with increasing household size, income, and number of workers.

³ ITE Trip Generation Manual, 10th Edition.

Table 6.4 HBW Trip Production Rates (Work)

Worker and Income Group	Household Size				
	1	2	3	4	5+
0 Workers					
Low	0.0000	0.0000	0.0000	0.0000	0.0000
Medium-low	0.0000	0.0000	0.0000	0.0000	0.0000
Medium	0.0000	0.0000	0.0000	0.0000	0.0000
Medium-high	0.0000	0.0000	0.0000	0.0000	0.0000
High	0.0000	0.0000	0.0000	0.0000	0.0000
1 Worker					
Low	1.0667	0.9610	1.9267	1.8535	2.2823
Medium-low	1.2312	0.9970	1.8018	1.8018	2.1622
Medium	1.2613	1.0330	1.7345	1.7658	2.0420
Medium-high	1.3622	1.2348	1.5015	1.7297	2.0132
High	1.4883	1.2372	1.3417	1.5616	1.9003
2+ Workers					
Low	0.0000	2.0420	2.7628	3.2264	3.6036
Medium-low	0.0000	2.1622	2.8444	3.2432	3.8438
Medium	0.0000	2.2823	3.0162	3.3898	3.9640
Medium-high	0.0000	2.5225	3.2793	4.0587	4.2883
High	0.0000	2.5616	3.3537	4.1622	4.5973

Source: Destino Travel Model, reviewed and updated for use in the RMS Model.

Table 6.5 HNWR Trip Production Rates (Retail)

Worker and Income Group	Household Size				
	1	2	3	4	5+
0 Workers					
Low	0.6426	1.8018	2.1622	1.9219	4.1093
Medium-low	0.7207	1.9219	2.2823	2.0096	4.3243
Medium	0.7988	2.1622	2.4360	2.1622	4.5646
Medium-high	0.9610	2.4024	2.5550	2.2823	4.8048
High	1.0931	2.5550	2.6426	2.4360	5.2877
1 Worker					
Low	0.4444	0.7916	1.7189	1.3213	1.8102
Medium-low	0.4625	1.1904	1.8595	1.5279	3.0174
Medium	0.4805	1.5652	1.9219	2.2823	3.2997
Medium-high	0.4997	1.8018	2.0408	2.6198	3.4450
High	0.5369	1.9856	2.5838	2.7688	5.2204
2+ Workers					
Low	0.0000	0.7255	1.0607	2.8709	3.3646
Medium-low	0.0000	1.0811	1.6721	2.8228	3.1315
Medium	0.0000	1.2709	1.8018	2.7447	2.2823
Medium-high	0.0000	1.4414	2.0060	2.6991	2.0613
High	0.0000	1.7393	2.2402	2.5225	1.6444

Source: Destino Travel Model, reviewed and updated for use in the RMS Model.

Table 6.6 HNWE1 Trip Production Rates (Kindergarten to Grade 12)

Worker and Income Group	Household Size				
	1	2	3	4	5+
0 Workers					
Low	0.1429	0.2523	1.4390	6.1369	9.0090
Medium-low	0.1141	0.2763	1.6817	2.6991	9.6096
Medium	0.0841	0.2883	1.9652	5.6276	10.2102
Medium-high	0.0721	0.3183	2.6426	9.2961	11.1375
High	0.0348	0.3604	2.8841	8.1453	11.2913
1 Worker					
Low	0.0120	0.1201	1.9940	6.0937	9.8258
Medium-low	0.0601	0.1453	2.1622	6.2907	12.1321
Medium	0.1021	0.2054	2.4024	6.6066	12.3724
Medium-high	0.1489	0.2643	2.5225	6.9429	12.6438
High	0.1802	0.3123	2.6426	7.6877	12.9730
2+ Workers					
Low	0.0000	0.4805	1.6817	3.6036	7.5676
Medium-low	0.0000	0.3604	1.5616	3.9640	7.6877
Medium	0.0000	0.3003	1.2012	4.3243	7.8078
Medium-high	0.0000	0.2402	1.0811	4.6018	8.2751
High	0.0000	0.1922	0.9610	5.2781	8.3483

Source: Destino Travel Model, reviewed and updated for use in the RMS Model.

Table 6.7 HNWE2 Trip Production Rates (College/University)

Worker and Income Group	Household Size				
	1	2	3	4	5+
0 Workers					
Low	0.0000	0.0000	0.3604	0.9610	0.4613
Medium-low	0.0000	0.0000	0.4805	1.0811	0.8144
Medium	0.0000	0.0120	0.6679	1.2697	1.3213
Medium-high	0.0000	0.0360	0.8024	1.3213	1.3886
High	0.3063	0.0721	1.0811	1.4871	1.4414
1 Worker					
Low	0.1297	0.0204	0.3604	0.4084	0.2402
Medium-low	0.4805	0.0541	0.4805	0.4805	0.3604
Medium	0.7207	0.0661	0.6607	0.6775	0.4805
Medium-high	0.9610	0.1153	0.7808	0.8408	0.7435
High	0.1321	0.1201	0.8408	1.1015	0.8408
2+ Workers					
Low	0.0000	1.1399	1.0811	1.4414	1.0907
Medium-low	0.0000	1.1171	0.9898	1.2072	1.0643
Medium	0.0000	1.0907	0.8408	1.1411	1.0210
Medium-high	0.0000	0.7147	0.6042	1.0811	0.9610
High	0.0000	0.4517	0.4661	1.0571	0.9333

Source: Destino Travel Model, reviewed and updated for use in the RMS Model.

Table 6.8 HNWO Trip Production Rates (Other)

Worker and Income Group	Household Size				
	1	2	3	4	5+
0 Workers					
Low	1.2396	1.7285	2.2222	3.2396	5.1652
Medium-low	1.2456	1.7429	2.2823	3.4835	5.4054
Medium	1.4571	1.7778	2.3411	3.9640	5.5255
Medium-high	1.5015	2.0420	2.4480	4.3243	5.6456
High	1.5255	2.3231	2.6426	4.6078	5.7658
1 Worker					
Low	0.5958	0.9177	1.2252	1.7153	3.0282
Medium-low	0.6246	1.3189	1.5616	1.9219	3.0426
Medium	0.6763	1.4414	1.6817	2.1285	4.0841
Medium-high	0.6967	1.5616	1.8030	3.1808	4.2847
High	0.7207	1.7405	2.0420	3.4186	7.8018
2+ Workers					
Low	0.0000	0.6006	0.8480	1.7874	1.8486
Medium-low	0.0000	0.6607	1.2384	2.1622	2.1622
Medium	0.0000	0.7447	1.4414	2.4024	3.2625
Medium-high	0.0000	1.0715	1.4751	2.8997	3.3634
High	0.0000	1.2432	2.0084	3.0018	3.4126

Source: Destino Travel Model, reviewed and updated for use in the RMS Model.

Table 6.9 NHB Trip Production Rates

Worker and Income Group	Household Size				
	1	2	3	4	5+
0 Workers					
Low	0.8825	1.6776	1.6144	3.0943	3.6324
Medium-low	1.1341	1.9292	2.0180	3.3634	3.8598
Medium	1.3453	2.5319	2.5077	3.4979	4.5674
Medium-high	1.5741	2.5562	2.6907	3.6324	5.6504
High	1.6144	2.6907	2.9598	3.7387	7.9927
1 Worker					
Low	0.5381	1.1583	1.8095	3.4777	4.1006
Medium-low	0.9417	1.3763	2.1526	3.4979	4.3051
Medium	1.2633	1.4799	2.6907	3.6324	4.6011
Medium-high	1.3346	1.4947	2.9046	3.8262	5.8590
High	1.3453	3.2517	2.9772	5.7635	9.1214
2+ Workers					
Low	0.0000	0.9417	1.3319	2.6907	5.1123
Medium-low	0.0000	1.4799	1.4893	2.9678	6.0540
Medium	0.0000	1.4987	2.3194	3.6324	6.4832
Medium-high	0.0000	1.9252	3.0378	4.3630	7.2649
High	0.0000	3.5800	4.9078	6.9837	7.6160

Source: Destino Travel Model, reviewed and updated for use in the RMS Model.

6.4 Attraction Rates

Attraction rates identify ends of trips located at places other than the trip-maker's home. For home-based trips, the attraction end of a trip occurs at a non-residential location, or occasionally at another person's home. For NHB trips, both trip productions and attractions occur at a non-home location. As documented previously, IE/EI trip attractions represent the internal trip-ends for all IE/EI trips, regardless of purpose. Attraction rates are defined for total households, employment by type, and school enrollment by type. Trip attraction rates also vary by area type. The attraction model structure and rates were retained from the Destino model and were not adjusted during the model validation process. Trip rates are shown in **Table 6.10**.

Table 6.10 Trip Attraction Rates

Trip Purpose	ATYPE	HH	BASIC EMP	RETAIL EMP	SERVICE EMP	EDUC EMP	K-12 ENROLL	COLL ENROLL
Home-Based Work (HBW)	1	0.0000	1.4872	1.6432	0.6760	1.2688	0.0000	0.0000
	2	0.0000	2.3816	1.1856	1.3208	1.2688	0.0000	0.0000
	3	0.0000	1.3624	2.2256	2.1216	1.3312	0.0000	0.0000
	4	0.0000	2.2464	2.5064	2.1632	1.3936	0.0000	0.0000
	5	0.0000	2.9120	6.9264	1.1856	1.0816	0.0000	0.0000
Home-Based Non Work Retail (HNWR)	1	0.0000	0.0000	1.9300	0.0000	0.0000	0.0000	0.0000
	2	0.0000	0.0000	3.5500	0.0000	0.0000	0.0000	0.0000
	3	0.0000	0.0000	5.7100	0.0000	0.0000	0.0000	0.0000
	4	0.0000	0.0000	7.8700	0.0000	0.0000	0.0000	0.0000
	5	0.0000	0.0000	8.0300	0.0000	0.0000	0.0000	0.0000
HBNW School (HNWE1)	1	0.0000	0.0000	0.0000	0.0000	0.0000	1.6500	0.0000
	2	0.0000	0.0000	0.0000	0.0000	0.0000	1.6500	0.0000
	3	0.0000	0.0000	0.0000	0.0000	0.0000	1.6500	0.0000
	4	0.0000	0.0000	0.0000	0.0000	0.0000	1.6500	0.0000
	5	0.0000	0.0000	0.0000	0.0000	0.0000	1.6500	0.0000
HBNW College (HNWE2)	1	0.0000	0.0000	0.0000	0.0000	0.0000	0.0000	1.2000
	2	0.0000	0.0000	0.0000	0.0000	0.0000	0.0000	1.2000
	3	0.0000	0.0000	0.0000	0.0000	0.0000	0.0000	1.2000
	4	0.0000	0.0000	0.0000	0.0000	0.0000	0.0000	1.2000
	5	0.0000	0.0000	0.0000	0.0000	0.0000	0.0000	1.2000
HBNW Other (HNWO)	1	0.9000	0.3848	1.6640	1.2272	2.4440	0.0000	0.0000
	2	0.9000	0.3016	1.4872	1.3728	2.4440	0.0000	0.0000
	3	0.9000	0.0936	2.3816	1.8616	2.4440	0.0000	0.0000
	4	0.9000	0.7488	3.0368	1.5392	2.4440	0.0000	0.0000
	5	0.9000	1.1128	3.7200	1.2168	1.8512	0.0000	0.0000

Trip Purpose	ATYPE	HH	BASIC EMP	RETAIL EMP	SERVICE EMP	EDUC EMP	K-12 ENROLL	COLL ENROLL
Non-Home Based (NHB)	1	0.0000	2.4232	7.6648	0.5096	2.3296	0.0000	0.0000
	2	0.0000	0.4472	5.8344	0.5824	2.3296	0.0000	0.0000
	3	0.0000	0.4472	5.8344	0.5824	2.3296	0.0000	0.0000
	4	0.0000	0.4472	5.8344	0.5824	2.3296	0.0000	0.0000
	5	0.0000	0.4472	5.8344	0.5824	2.3296	0.0000	0.0000
Light Trucks (LT)	1	0.3770	0.1375	0.3142	0.1375	0.1375	0.0000	0.0000
	2	0.3770	0.1375	0.3142	0.1375	0.1375	0.0000	0.0000
	3	0.3770	0.1375	0.3142	0.1375	0.1375	0.0000	0.0000
	4	0.3770	0.1375	0.3142	0.1375	0.1375	0.0000	0.0000
	5	0.3770	0.1375	0.3142	0.1375	0.1375	0.0000	0.0000
Medium Trucks (MT)	1	0.3829	0.1192	0.4618	0.1192	0.1192	0.0000	0.0000
	2	0.3829	0.1192	0.4618	0.1192	0.1192	0.0000	0.0000
	3	0.3829	0.1192	0.4618	0.1192	0.1192	0.0000	0.0000
	4	0.3829	0.1192	0.4618	0.1192	0.1192	0.0000	0.0000
	5	0.3829	0.1192	0.4618	0.1192	0.1192	0.0000	0.0000
Heavy Trucks (HT)	1	0.0119	0.0356	0.0901	0.0356	0.0356	0.0000	0.0000
	2	0.0119	0.0356	0.0901	0.0356	0.0356	0.0000	0.0000
	3	0.0119	0.0356	0.0901	0.0356	0.0356	0.0000	0.0000
	4	0.0119	0.0356	0.0901	0.0356	0.0356	0.0000	0.0000
	5	0.0119	0.0356	0.0901	0.0356	0.0356	0.0000	0.0000
External Internal (EXTINT)	1	0.0000	0.8008	1.8512	0.0520	0.0000	0.0000	0.0000
	2	0.0000	0.3016	2.1424	0.1456	0.0208	0.0000	0.0000
	3	0.0000	0.4472	3.1200	0.1040	0.1560	0.0000	0.0000
	4	0.0000	0.2600	0.6032	0.0416	0.1456	0.0000	0.0000
	5	0.0000	0.0000	8.2576	0.1352	0.0000	0.0000	0.0000

Source: Destino Travel Model, reviewed and retained for use in the RMS Model.

6.5 Income Segmentation

TripCAL6 outputs productions and attractions by trip purpose for each zone. However, the trip distribution and mode choice models include market segmentation by income group. This requires separation of home-based trips into the five income groups described previously. The RMS model post-processes TripCAL 6 production and attraction tables to include market segmentation. For productions, trips are segmented into income groups using the share of households by income in each TAZ. For attractions, trip-ends are segmented uniformly in all TAZs based on the regional distribution of households by income group.

6.6 Special Generators

The RMS Model uses special generators to represent places with a high level of activity that is not well represented by the standard Trip Generation model. Included special generators are the University of Texas at El Paso (UTEP), the El Paso International Airport, and Fort Bliss Military Base. Other colleges and universities in the region are smaller in size, have limited or no on-campus housing, and are reasonably represented by the trip generation rates described in **Section 6.2** and **Section 6.3**.

6.6.1 University of Texas at El Paso (UTEP)

Located just northwest of downtown El Paso, UTEP is a four-year university with enrollment of about 25,000 students. UTEP students tend to live on or near campus, resulting in unique trip generation patterns. The university is made up of the six traffic analysis zones shown in **Figure 6.1**. The TAZs contain a combination of classrooms, offices, and on-campus housing. Some university zones also contain other non-university uses such as off-campus housing and commercial activities.

Figure 6.1 UTEP Traffic Analysis Zones

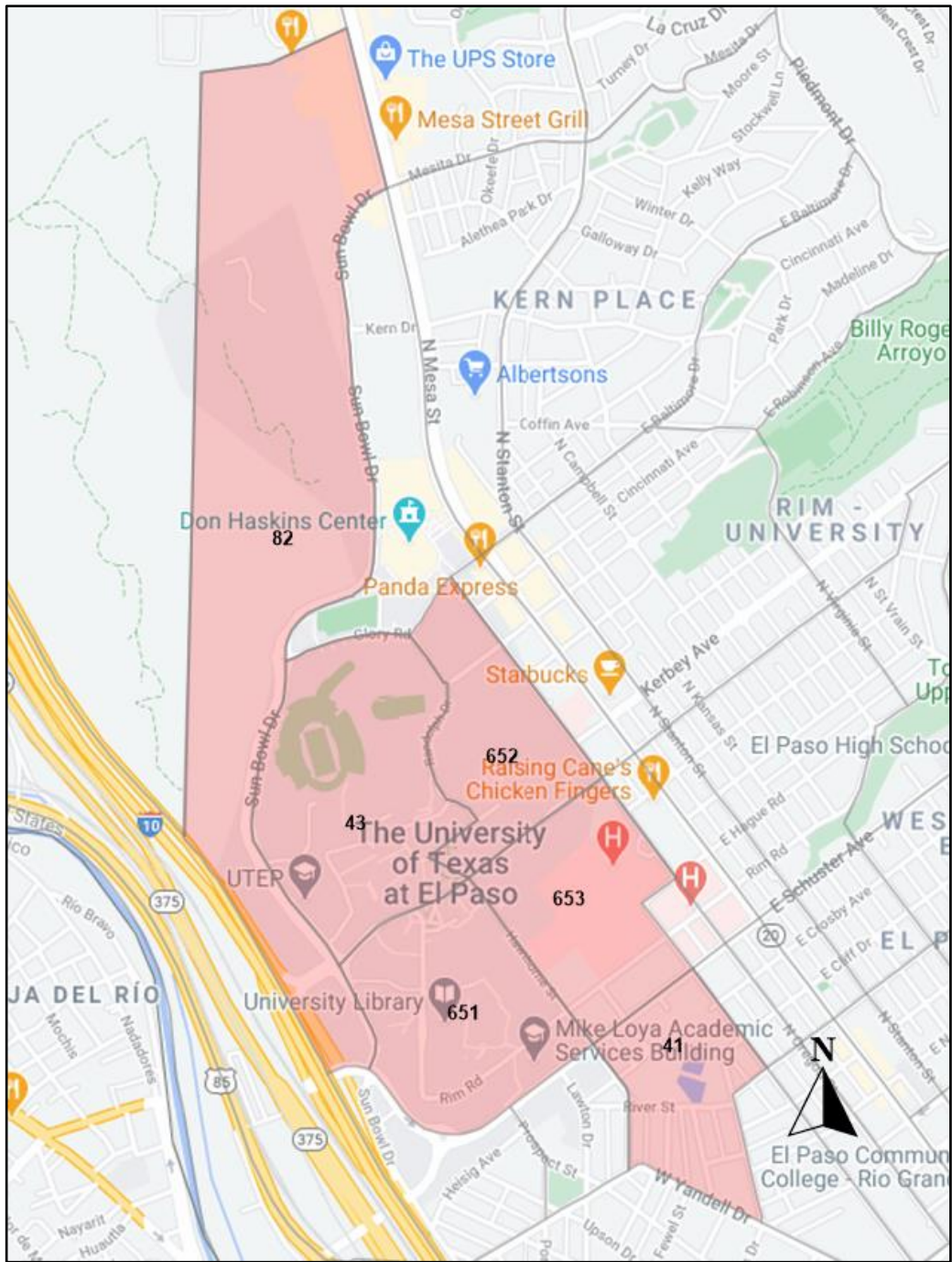

University Trip Purposes

Because UTEP does not fall into the normal trip patterns used by the model in the remainder of the region, some special considerations are given to trip types at universities. In particular, the Home-Based Non-Work Education 2 (HBNWE2) trip purpose is defined as a trip by a university student or visitor between an off-campus home and any location on the university campus. Other trip ends at the university are associated with university faculty and staff, students living on campus, and students and visitors living off campus. Descriptions of how each trip purpose are addressed at university special generators are presented below.

- **HBW, HBNWR, and HBNWO Productions:** These production trip ends at the University can occur only for students living on campus.
- **HBW Attractions and NHBW Productions:** These trip ends at the University can occur only for University faculty and staff.
- **NHBW Attractions and all NHBO Trips:** These trip ends at the University can only occur for students and visitors living off campus.
- **HBNWR and HBNWO Attractions:** These trip ends cannot occur at the university. All home-based trips to the university by students and visitors are considered HBNWE22 trips and all home-based trips to the university by faculty and staff are considered HBW trips.
- **HBNWE2 Productions:** Trips within the university campuses are not modeled, so HBNWE2 productions cannot occur on campus.
- **HBNWE2 Attractions:** HBNWE2 on-campus attractions can occur only for students and visitors living off campus and traveling to campus.

Employment and Enrollment Data

UTEP special generator trip generation is based on 2017 employment and enrollment totals. For the 2017 base year, UTEP is modeled as having 2,844 employees and 24,879 enrolled students. Based on an information about on-campus housing capacity provided available on the university website, 7,464 students are modeled as living on-campus with the remaining 17,415 students modeled as off-campus.

Special Generator Model

Trips for the UTEP special generator are based on a pair of special generator studies conducted at two universities in Colorado: Colorado State University (CSU) in 1999 and the University of Northern Colorado (UNC) in 2004. These surveys included a complete cordon count, student intercept surveys, and faculty and staff trip diary surveys. Trip rates based on the survey are defined in units of trips per on-campus student, trips per off-campus student, or trips per employee. Trip rates and resulting special generator values were applied to UTEP and scaled as needed to match traffic counts surrounding the university. Resulting trip rates and special generator values are shown in **Table 6.11**.

Special generator trips are distributed in the model to the six zones that make up UTEP. This has been done based on a review of the type of activity in each zone, along with analysis of trip activity by zone as indicated by LBS data.

Table 6.11 UTEP Special Generator Values

Trip Purpose	Production / Attraction	Trip Rate	Unit	Generator Value	Special Generator Trips
HBW	Productions	0.18	On Campus Students	7,464	1,343
	Attractions	1.28	Total Employment	2,844	3,640
HBNWR	Productions	0.16	On Campus Students	7,464	1,194
	Attractions	n/a	n/a		0
HBNWE2	Productions	n/a	n/a		0
	Attractions	3.04	Off Campus Students	17,415	52,943
HBNWO	Productions	0.40	On Campus Students	7,464	2,985
	Attractions	n/a	n/a		0
NHB	Productions	0.15	Total Employment + Off-Campus Students	20,259	3,039
	Attractions	0.18	Off Campus Students	17,415	3,135

Source: Adapted from CSU and UNC special generator surveys.

6.6.2 Fort Bliss

Fort Bliss consists of 19 traffic analysis zones, shown in **Figure 6.2** and **Figure 6.3**. Access to Fort Bliss is limited to a select number of gates, represented in the model by connections to the highway network outside of the base. Total Fort Bliss activity has been defined based on total base employment of 44,233 multiplied by a calibrated special generator trip rate of 0.65 trips per employee. This trip rate was carried forward from the Destino model, then results were compared to LBS and traffic count data.

Employment data at Fort Bliss does not coincide with places where activity occurs, nor is it particularly useful in defining trip purposes. Instead, special generator trip-ends were assigned to trip purposes and distributed to Fort Bliss TAZs based on an analysis of LBS data, as shown in **Table 6.12**. Adjustments to an initial special generator implementation based on LBS data analysis resulted in significant improvements to the model's ability to match traffic counts near Fort Bliss.

Table 6.12 Fort Bliss Special Generator Trip Distribution

TAZ	HBW Productions	HNWO Productions	NHB Productions	HBW Attractions	HNWO Attractions	NHB Attractions
166	2	20	31	3	18	30
167	51	210	221	44	228	206
168	33	535	828	38	401	964
169	9	45	215	12	63	193
170	203	248	136	160	271	161
171	49	318	382	42	354	358
172	313	531	343	276	571	323
173	111	57	307	127	75	274
174	170	146	297	192	138	276
175	180	75	420	241	93	334
176	1,160	285	1,979	1,430	301	1,743
177	26	41	109	26	51	102
178	39	61	56	35	68	38
214	4	18	17	4	18	19
215	33	63	79	27	63	86
486	281	978	1,576	287	1,047	1,496
487	54	323	465	60	337	447
623	6	20	111	8	32	97
825	6	24	64	8	36	52

Source: Destino model special generator, revised based on analysis of LBS data

6.6.3 El Paso International Airport

El Paso International Airport is represented by TAZ 230, identified in **Figure 6.2** and **Figure 6.3**. Due to the unique nature of airport trips, the airport is modeled as a special generator. The airport is represented by an overall special generator trip rate of 2.5 trips per employee, carried over from the Destino Model. This value was adjusted to match traffic counts immediately near airport entrances and exits.

Airport trips are separated into HBW, HBNWO, and NHB trips. Trip purposes have been assigned based on the distribution of trip purposes obtained from LBS data, as shown in Table 6.13.

Table 6.13 Airport Special Generator Trip Distribution

TAZ	HBW Productions	HNWO Productions	NHB Productions	HBW Attractions	HNWO Attractions	NHB Attractions
230	97	371	979	114	566	1,083

Source: Destino model special generator, revised based on analysis of LBS data

Figure 6.2 Fort Bliss and Airport Zones (Overview)

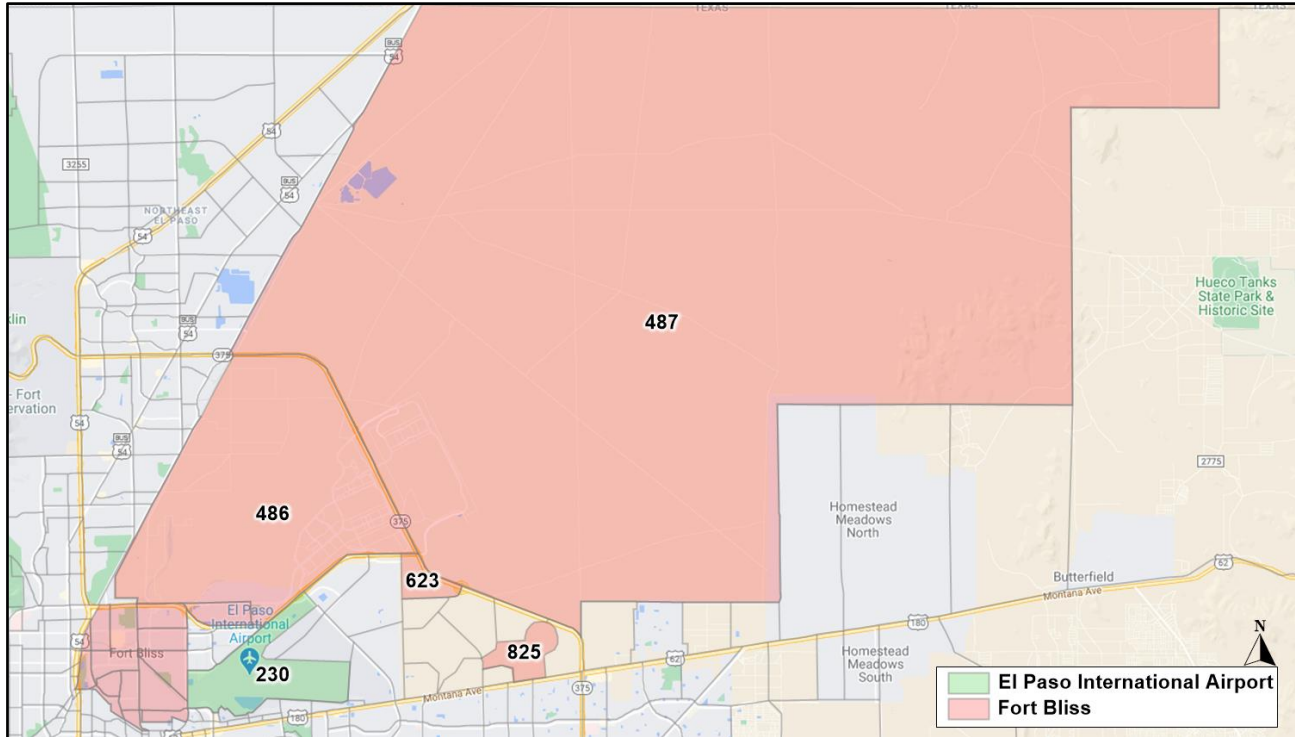
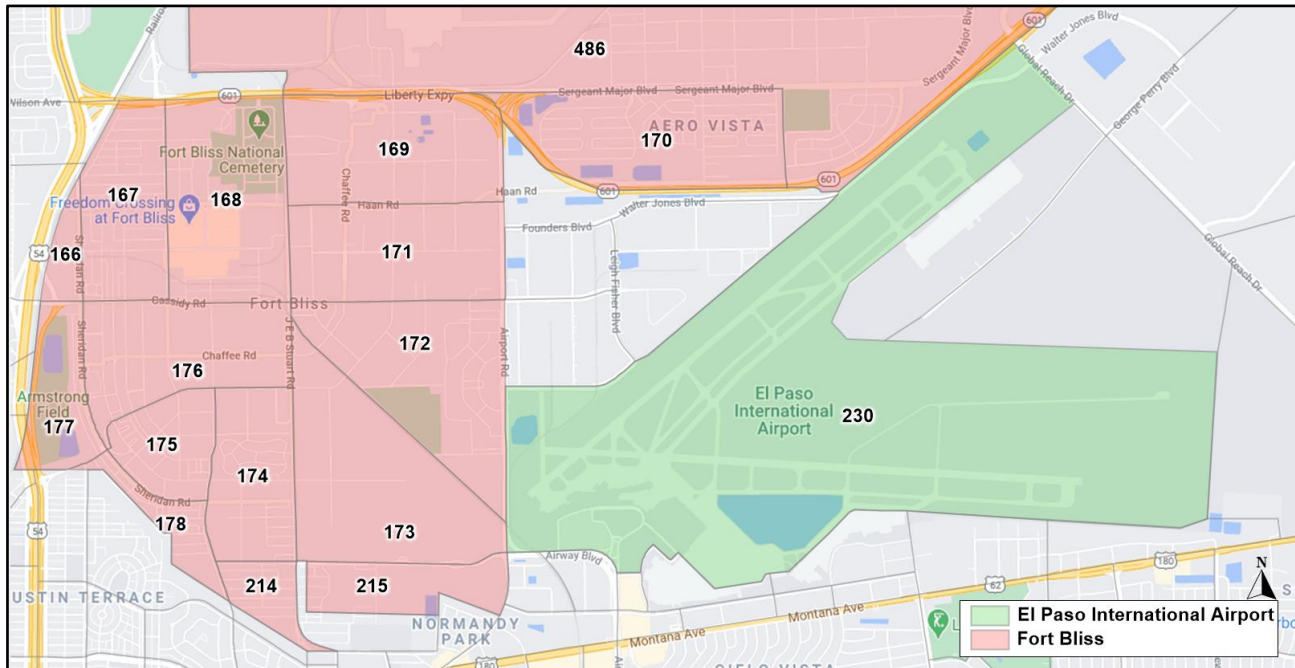

Figure 6.3 Fort Bliss and Airport Zones (Detail)



6.6.4 Special Generator Forecasting

Special generators can be difficult to forecast due to the unique nature of special generator uses. The following assumptions have been made for special generators in the RMS Model.

- **UTEP** is assumed to grow at the same rate as population in the region.
- **Fort Bliss** is assumed to remain the same in interim and forecast years.
- **El Paso International Airport** is assumed to grow at the same rate as population in the region.

6.7 Trip Balancing

After application of production and attraction rates, the total number of trip productions and attractions may not match, especially when considering trip production rate increase introduced to match total VMT. It is necessary to scale or “balance” either productions or attractions so that production and attraction totals are equal for each trip purpose. For most trip purposes, trips are balanced to productions. This is done due to a higher level of confidence in the US Census-based household data underlying trip production models. There are several deviations and caveats to this approach, described below.

- HNWE2 (College/university) trips are balanced to trip attractions. This method has been chosen due to the high level of confidence in enrollment data at colleges and universities. This approach also allows the model to vary the amount of traffic to and from these isolated locations by changing enrollment input data.
- While NHB trips are balanced to productions, they are re-allocated to non-home locations.
- Because truck trips are not generated by the household-based trip production models, truck trips are balanced to attractions.

7.0 Trip Distribution

Trip distribution is the second phase of the traditional four step travel model. Trip distribution is the process through which trip productions and attractions from the trip generation model are apportioned between all zone pairs in the modeling domain. The resulting trip table matrix contains both intrazonal trips (i.e., trips that do not leave the zone) on the diagonal and interzonal trips in all other zone interchange cells for each trip purpose.

7.1 Peak and Off-peak Period Definitions

The RMS Model uses TransCAD’s built-in gravity model to distribute trips. The model distributes trips occurring during the AM and PM peak periods using peak congested speeds, and distributes trips occurring during mid-day and overnight periods using off-peak congested speeds. Trip distribution is performed in Production-Attraction (PA) format rather than Origin-Destination (OD) format because the majority of trips in the AM peak period travel from production to attraction (e.g., to work) and the majority of trips in the PM peak period travel from attraction to production (e.g., from work). The model uses congested travel times to distribute productions and attractions using a doubly constrained gravity model.

To implement trip distribution by time of day, factors representing the portion of trips occurring in the combined AM and PM peak period and separately in the off-peak time period are necessary. Trips are further separated into more detailed peak periods during the time of day step prior to traffic assignment. Trip distribution time of day factors based on the 2010-2011 Household Travel Survey data are shown in **Table 7.1**.

Table 7.1 Trip Distribution Time of Day Factors

	HBW	HNWE1	HNWE2	HNWR	HNWO	NHB	LT	MT	HT	EXTINT
Peak	62.7%	92.9%	40.0%	35.9%	42.7%	53.1%	53.1%	53.1%	53.1%	53.1%
Off-Peak	37.3%	7.1%	60.0%	64.1%	57.3%	46.9%	46.9%	46.9%	46.9%	46.9%

Source: Destino Travel Model, reviewed and updated for use in the RMS Model.

7.2 Gravity Model

The gravity model applies friction factors to represent the effects of impedance between zones. As the impedance between zones increases, the number of trips between those zones decreases as represented by a decreasing friction factor. The gravity model also assumes that the number of trips between two zones is directly proportional to the number of productions and attractions contained in those zones. The gravity model is defined in the equation below.

$$T_{ij} = P_i \cdot \frac{A_j \cdot F_{ij} \cdot K_{ij}}{\sum_{i=1}^n (A_j \cdot F_{ij} \cdot K_{ij})}$$

Where:

- T_{ij} = trips from zone i to zone j
- P_i = productions in zone i
- A_j = attractions in zone j
- K_{ij} = K-factor adjustment from i to zone j
- i = production zone
- j = attraction zone
- n = total number of zones
- F_{ij} = friction factor (a function of impedance between zones i and j)

Doubly constraining the gravity model means that the total number of productions and attractions resulting from trip generation is maintained at the TAZ level.

7.2.1 Friction Factors

Friction factors represent the impedance to travel between each zone pair. The RMS Model applies friction factors in the form of gamma functions, defined by the equation below. Gamma function parameters are defined in **Table 7.2** and **Table 7.3**. Calibration of these parameters is described in **Section 11.2**.

$$F_{ij} = \alpha t^{-\beta} e^{-\gamma t}$$

Where:

- F_{ij} = friction factor between zones i and j
- t = travel time
- α, β, γ = calibration parameters

Table 7.2 Gravity Model Friction Factors (Peak)

	HBW	HNWE1	HNWE2	HNWR	HNWO	NHB	LT	MT	HT	EXTINT
Alpha	99.999	999.999	999.999	1671.979	999.986	999.899	155.659	155.659	155.659	999.899
Beta	0.260	0.700	0.600	0.3595	0.450	0.4099	0.000	0.000	0.000	0.4099
Gamma	0.080	0.670	0.320	0.2495	0.125	0.117	0.0885	0.0885	0.0885	0.160

Source: El Paso RMS Model.

Table 7.3 Gravity Model Friction Factors (Off-Peak)

	HBW	HNWE1	HNWE2	HNWR	HNWO	NHB	LT	MT	HT	EXTINT
Alpha	99.999	999.999	999.999	1671.979	999.986	999.899	155.659	155.659	155.659	999.899
Beta	0.260	0.700	0.600	0.3595	0.470	0.4299	0.000	0.000	0.000	0.4099
Gamma	0.095	0.670	0.320	0.2495	0.145	0.137	0.0885	0.0885	0.0885	0.160

Source: El Paso RMS Model.

8.0 Vehicle Availability Model

The vehicle availability, applied after trip generation, allows consideration of auto availability in the mode choice model. The model is specified as a discrete choice model with five alternatives:

- 0-vehicles available;
- 1-vehicle available;
- 2-vehicles available;
- 3-vehicles available; and
- 4-vehicles or more available.

Because the dependent variable (vehicles) demonstrates a natural ordering, the ordered logit (ORL) model form was chosen to model the choice. The ORL model is specifically suited for choice contexts where the alternatives follow a natural ordering. Whereas a multinomial logit (MNL) treats each choice alternative distinctly and estimates the coefficients of linear (latent) utility functions specific for each alternative, the ORL assumes a single latent function (modeled as a linear function of explanatory variables, similar to MNL), which measures the propensity for a household to own more or less vehicles. The higher the latent variable for a specific household, the more likely that household is to own a higher number of vehicles.

8.1 Variables

Household characteristic variables available for this model are limited to those variables that are generated by TripCal6, including income, household size, and number of workers. Each of these variables was tested during model estimation and included in the final model.

Two locational attributes of a household's zone are included in the model. The first is the land use density at the home zone, which takes the following function form:

$$Density = Ln \left(1 + \frac{Population + 2.0 \times Employment}{Acres} \right)$$

The second variable is a measure of relative transit accessibility. Transit accessibility is important to vehicle ownership, since having transit accessibility allows for lower auto ownership rates than areas with more limited transit accessibility. Transit accessibility is measured relative to roadway accessibility since transit networks and highway networks typically share many characteristics spatially.

$$Acc_i = A_{i,DA} - A_{i,TW}$$

Here, Acc_i is the relative transit accessibility, $A_{i,DA}$ is the absolute highway accessibility, and $A_{i,TW}$ is the absolute transit accessibility. The absolute accessibilities are computed as follows:

$$A_{im} = \ln \left[\sum_j S_j \times \exp(U_{ijm}) \right]$$

Here, the sum is across all zones in the region, S_j is the size of the zone (measured as total employment in the zone), and U_{ijm} is an idealized mode utility from zone i to zone j by mode m . Table 8.1 shows the parameters assumed for the utility function for this variable. These parameter values are based on values typically found in similar regions across the U.S. Separate accessibilities are computed for low and high income households. The variable differs in the cost coefficient used in the utility function, as shown in **Table 8.1**.

Table 8.1 Utility Parameters for Accessibility Variables

Mode	Variable	Value
All	In-Vehicle Travel Time	-0.025
All	Cost – Low Income (Cat = 1,2)	-0.200
All	Cost – High Income (Cat = 3,4,5)	-0.100
TW	Transfers	-0.100
TW	Local Bus Used (0/1)	-1.000
TW	OVT Ratio	2.500

Source: Destino Travel Model, reviewed and retained for use in the RMS Model.

The estimation results are presented in **Table 8.2**. Some of the key findings of the vehicle availability model estimation are as follows:

- All else being equal, higher income households have higher propensity to own vehicles;
- Household size and number of workers both have positive impacts on the vehicle availability propensity;
- Land use density in the home zone has a negative relationship to the propensity to own vehicles, which makes sense since denser areas have more employment centers more closely spaced, making non-auto modes more viable.
- Relative transit accessibility has a positive effect on the propensity to own vehicles. This makes sense, since relative transit accessibility is defined as the difference between highway and transit accessibility. The better the highway accessibility, the higher the value of the variable. We would expect when highway accessibility is high, households will own more vehicles.

8.2 Model Estimation

Vehicle availability model estimation results are shown in Table 8.2.

Table 8.2 Vehicle Availability Model Estimation Results

Variable		Coefficient	t-stat
Income Category	Medium-low	0.32	2.5
	Medium	0.97	7.8
	Medium-high	1.38	11.2
	High	1.80	13.8
Household Size	2 persons	1.58	12.1
	3 persons	2.35	17.0
	4 persons	2.50	17.8
	5 persons	2.81	19.0
Workers	1 worker	0.29	3.3
	2 workers	1.28	11.9
Zonal	Relative Transit Access	0.11	1.6
	Land Use Density	-0.17	-2.9
Thetas	0 1	-1.31	-6.3
	1 2	1.95	9.6
	2 3	4.61	21.2
	3 4	6.35	27.9
Number of Observations		2892	
Log Likelihood of Model		-3205.0	
Log Likelihood of Constants Only		-3842.1	
Rho Squared		0.166	

Source: Destino Travel Model, reviewed and retained for use in the RMS Model.

8.3 Model Calibration

The thetas shown in the table were not discussed earlier. These serve the same purpose as alternative specific constants in an MNL model, but are the ORL model’s equivalent. They ensure that the model replicates the alternative shares represented in the survey data. The ORL uses only a single latent variable and the thetas assign the breakpoints at which a household’s propensity to own more or less vehicles actually manifests in changing auto ownership level. The first theta (0|1) represents the breakpoint between 0 and 1 vehicles, the second (1|2) represents the breakpoint between 1 and 2 vehicles, and so on. To illustrate how the model works, consider shifting from a propensity of 1.5 to 2.0, which will result in a shift of owning 1 vehicle to 2 vehicles. However, shifting from a propensity of 1.0 to 1.5 results in no change in auto ownership (one vehicle is owned at both propensity levels). The calibrated theta parameters are provided in **Table 8.3**.

Table 8.3 Theta Values for the Vehicle Availability Model

Coefficient	Estimated Value	Calibrated Value
Theta 1	-1.31	-1.50
Theta 2	1.95	2.26
Theta 3	4.61	4.92
Theta 4	6.35	6.66

Source: Destino Travel Model, reviewed and retained for use in the RMS Model.

Model validation results, presented in **Table 8.4**, evaluate three vehicle sufficiency categories that combine auto ownership model results with the number of household workers. These vehicle sufficiency values listed below, are used in the mode choice model.

1. Zero vehicles;
2. Vehicles less than workers, greater than zero; and
3. Vehicles greater than or equal to workers and greater than zero.

Table 8.4 shows the expanded survey versus modeled vehicle availability shares.

Table 8.4 Vehicle Sufficiency Validation

Vehicle Category	Expanded Survey	Modeled
Zero Vehicles	3.5%	3.6%
Vehicles < Workers	52.9%	53.2%
Vehicles >= Workers	43.6%	43.2%

Source: Cambridge Systematics analysis of 2010-2011 Household Travel Survey data, RMS Model results.

9.0 Mode Choice

The RMS Model produces and distributes all person trips including non-motorized, auto, and transit trips. The mode choice model separates the resulting person trip tables into drive alone, shared ride by occupancy (2 and 3+ occupancy), transit (walk access and drive access), and non-motorized (bicycle and walk) modes. Roadway and transit networks provide important input to the mode choice model and include information about bicycle facilities. The mode choice model considers trip lengths produced by the trip distribution model, resulting in sensitivity to higher density and mixed-use areas. Such areas produce shorter trips which are more likely to be made using non-motorized modes.

9.1 Observed Mode Shares

9.1.1 Non-Transit Mode Shares

The mode choice model has been calibrated to reproduce observed mode shares. Observed mode share values for auto trips and non-motorized trips are based on data from the 2010-2011 Household Travel Survey. **Table 9.1** shows the non-transit trip calibration targets.

A review of the household travel survey revealed that 9.6% of school trips happen on school buses. Consequently, school trips were factored down by 9.6% before mode choice, as school bus is not a mode that is considered in the El Paso RMS mode choice model.

Table 9.1 Non-Transit Trip Targets

Purpose	SOV	HOV2	HOV3+	Bike	Walk
HBW Low Inc	86%	7%	6%	0%	1%
HBW Med-Low Inc	86%	7%	3%	0%	4%
HBW Med Inc	90%	9%	1%	0%	1%
HBW Med-High Inc	91%	8%	1%	0%	0%
HBW High Inc	93%	5%	1%	0%	0%
HNWE1 Low Inc	14%	32%	41%	2%	11%
HNWE1 Med-Low Inc	12%	27%	43%	1%	17%
HNWE1 Med Inc	14%	27%	47%	0%	11%
HNWE1 Med-High Inc	15%	31%	43%	0%	11%
HNWE1 High Inc	18%	32%	43%	1%	6%
HNWE2 Low Inc	70%	28%	2%	0%	0%
HNWE2 Med-Low Inc	79%	21%	0%	0%	0%
HNWE2 Med Inc	66%	25%	5%	1%	4%
HNWE2 Med-High Inc	67%	24%	10%	0%	0%
HNWE2 High Inc	72%	17%	11%	0%	0%
HNWR Low Inc	38%	37%	24%	0%	1%
HNWR Med-Low Inc	34%	35%	27%	0%	4%
HNWR Med Inc	39%	39%	21%	0%	1%
HNWR Med-High Inc	41%	33%	25%	0%	1%
HNWR High Inc	40%	31%	28%	0%	1%
HNWO Low Inc	29%	40%	26%	0%	4%
HNWO Med-Low Inc	33%	27%	30%	1%	9%
HNWO Med Inc	37%	32%	24%	0%	7%
HNWO Med-High Inc	36%	34%	26%	0%	3%
HNWO High Inc	36%	26%	32%	1%	6%
NHBW	83%	12%	3%	0%	2%
NHBO	30%	37%	30%	0%	3%

Source: Cambridge Systematics analysis of 2010-2011 Household Travel Survey data.

9.1.2 Observed Transit Trips

For transit trips, total transit boardings were obtained from Sun Metro and El Paso County, as shown in **Table 9.2**. Transit boarding data cannot be directly used as mode choice calibration targets because they include transfers and need to be converted to complete origin-to-destination trips, or linked transit trips. In addition, transit boardings need to be separated by trip purpose and income to support model calibration. The 2010-2011 Household Travel Survey did not contain enough records to convert boardings to trips or to separate transit trips by purpose or income. This data is sometimes available from on-board surveys conducted by transit agencies, but not all agencies collect this data.

For the RMS model, boardings were converted to linked trips using an average transfer rate of 1.45 provided by Sun Metro. Because 2012 El Paso on-board survey data were not sufficient to segment transit trips by income, targets by income group are based on data transferred from a 2014 on-board survey conducted by VIA Transit in San Antonio, TX.

Table 9.2 2017 Fixed Route Boardings

<u>Operator</u>	<u>Average Weekday Boardings</u>
Sun Metro	39,638
El Paso County	234
Total	39,872

Source: Data provided by El Paso area transit agencies.

The RMS Model represents two transit access modes: walk access⁴ and drive access. Walk access includes all non-motorized transit access and implicitly includes kiss-n-ride access to stops that are not formal park-n-rides. Drive access includes transit trips that make use of one of the formal park-n-rides shown in **Figure 9.1**. Transit trips were separated into walk and drive access based on survey data, resulting in the shares shown in **Table 9.3**.

Table 9.3 Observed Walk and Drive Access Shares

<u>Access Mode</u>	<u>Share of Trips</u>
Walk and bike	94%
Drive	6%

Source: Cambridge Systematics analysis of 2010-2011 Household Travel Survey data

⁴ Bicycle access and egress to transit is not modeled explicitly but is instead modeled as walk access and egress.

Figure 9.1 2017 Park-n-Ride Locations

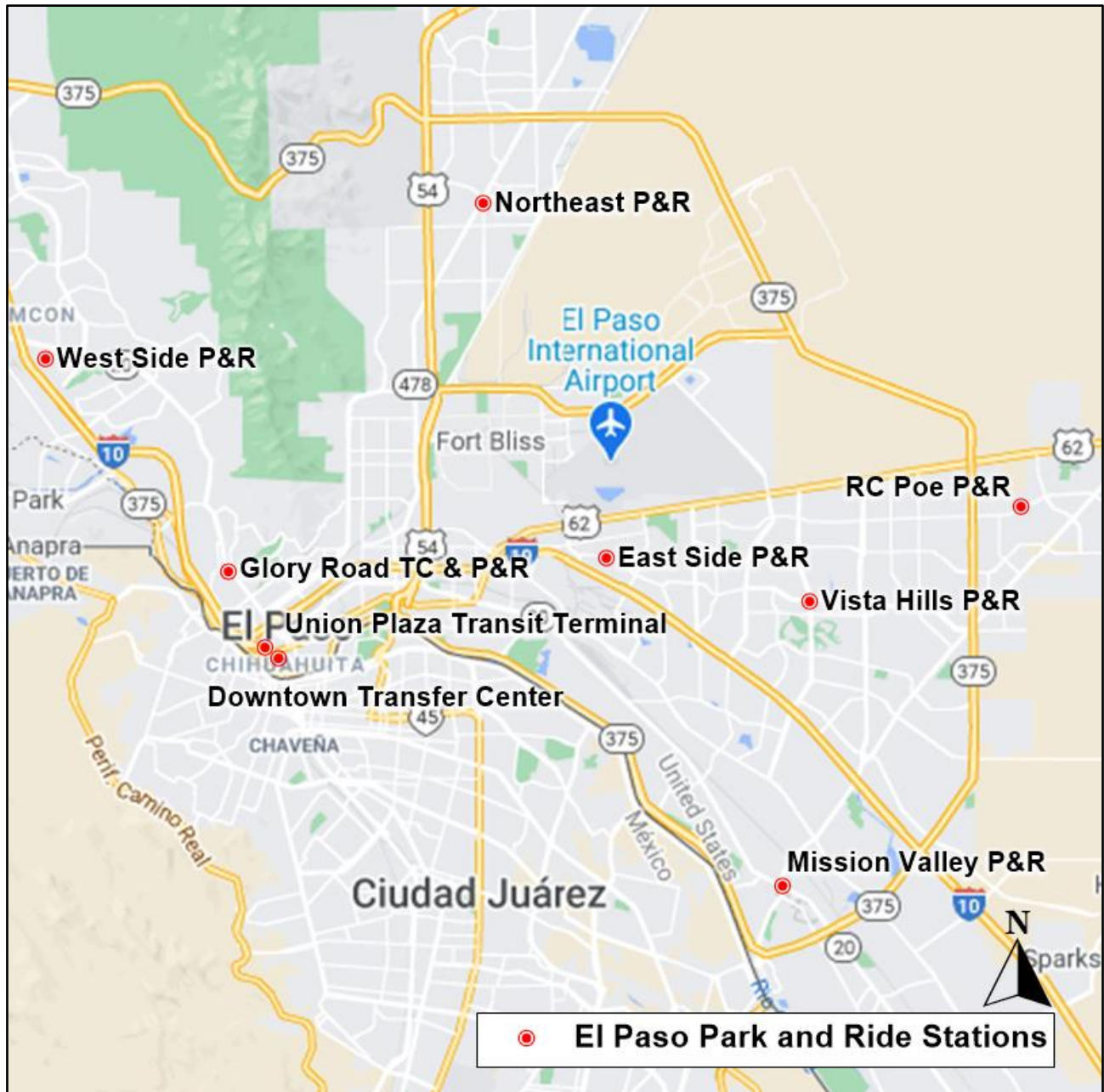

Based on the analysis described above, regional transit trip targets can be prepared based on income, trip purpose, and transit access mode. Transit calibration targets are shown in **Table 9.4**, expressed as number of linked trips. Transit targets are computed in number of linked trips rather than as a percent share of overall travel to ensure that small changes in trip totals that may occur during model calibration do not change the transit targets that have been developed based on observed data. These targets are combined with the auto and non-motorized mode share targets discussed previously to form a complete set of mode choice calibration targets.

Table 9.4 Resulting Transit Trip Targets

Purpose	Drive to Transit	Walk to Transit	Total Transit Linked Trips
HBW Low Inc	165	3,005	3,171
HBW Med-Low Inc	90	1,369	1,458
HBW Med Inc	30	213	243
HBW Med-High Inc	10	40	50
HBW High Inc	14	33	47
HNWE1 Low Inc	87	972	1,059
HNWE1 Med-Low Inc	16	200	217
HNWE1 Med Inc	2	51	53
HNWE1 Med-High Inc	0	8	8
HNWE1 High Inc	0	7	7
HNWE2 Low Inc	170	1,978	2,148
HNWE2 Med-Low Inc	82	737	818
HNWE2 Med Inc	29	194	224
HNWE2 Med-High Inc	0	73	73
HNWE2 High Inc	0	7	7
HNWR Low Inc	347	4,244	4,591
HNWR Med-Low Inc	36	962	999
HNWR Med Inc	4	110	114
HNWR Med-High Inc	0	15	15
HNWR High Inc	0	5	5
HNWO Low Inc	248	5,185	5,433
HNWO Med-Low Inc	86	1,422	1,509
HNWO Med Inc	31	169	200
HNWO Med-High Inc	13	44	56
HNWO High Inc	1	17	18
NHBW	52	1,053	1,105
NHBO	232	3,640	3,871
Total	1,744	25,755	27,498

Source: Cambridge Systematics analysis of on-board Survey Data and 2017 Transit Boarding Data

9.2 Mode Choice Model Structure

The RMS Model applies a logit-based mode choice model for all internal trip purposes. The general equation describing a multinomial mode choice is shown in the equation below.

$$P_i = \frac{e^{U_i}}{\sum_{m=1}^n e^{U_m}}$$

Where:

- P_i = the probability of using mode i
- u_i = the utility of mode i
- u_m = the utility of mode m
- n = the number of modes

The logit model is based on the concept of utilities (or dis-utilities) that describe the characteristics of travel by each mode. The utility function can be made up of impedance variables such as travel time, wait time, and cost as well as locational and socioeconomic variables. Each variable is multiplied by an estimated coefficient that describes the relative weight (positive or negative) of each variable. A mode constant that captures mode preferences not measured by the other utility variables is also added to the utility. Due to the relative nature of the mode constants, the mode constant for one mode must be set to zero. The utility equation applied to each mode is shown below.

$$u_i = c_1X_{1i} + c_2x_{2i} + c_3x_{3i} + \dots + c_nx_{ni} + K$$

Where:

- u_i = Utility for mode i
- $c_1, c_2, c_3, \dots, c_n$ = Estimated coefficients for variables 1 through n
- $x_{1i}, x_{2i}, x_{3i}, \dots, x_{ni}$ = Values for variables 1 through n
- K = Alternative Specific Constant

The RMS Model uses a mode choice structure that nests multiple multinomial choices. At the bottom level of the nested logit structure, utility values are computed using the method described for multinomial application. Utilities at the upper level are computed as a combination of utilities for the nested modes (i.e., modes below the upper level choice). An example of a lower level mode is walk, while the corresponding upper level mode is non-motorized. Utilities for intermediate modes are based on the natural log of the sum of exponentiated sub-mode utilities. This term, referred to as the “logsum” variable, is computed as shown below.

$$LS_i = \ln \left(\sum_{j=1}^n e^{u_j} \right)$$

Where:

- LS_i = The logsum of intermediate mode i
- u_j = Utility terms for nested mode j
- n = The number of sub-modes under mode i

Once the logsum variables have been computed for all intermediate modes, mode probabilities are calculated in a manner similar to that described for multinomial logit models. However, for nested modes, utilities are replaced by the product of the logsum and a nesting coefficient as shown in the equation below. The nesting coefficient has a value between zero and one, where a nesting value of zero indicates sub-modes are identical and do not need to be included as separate modes and a nesting value of one indicates sub-modes are distinctly different and could be represented as separate non-nested modes.

$$P_i = \frac{e^{\theta_i \cdot LS_i}}{\sum_{m=1}^n e^{\theta_m \cdot LS_m}}$$

Where:

- P_i = The probability of selecting intermediate mode i
- θ_i = The nesting coefficient for intermediate mode i
- θ_m = The nesting coefficient for mode m
- n = The number of modes at the same level as mode i

The structure for the El Paso mode choice models, shown in **Figure 9.2**, assumes modes, sub-modes, and access modes are distinctly different types of alternatives that present distinct choices to travelers. Within each nest, the model operates on the modes included in the nest as a multinomial logit model. Likewise, the model operates on nests included at a specific nesting level as a multinomial logit model. However, the competition between modes included in different nests or nesting levels is not in proportion to initial estimates of the mode shares. As a result, an important departure from multinomial logit models is “lower level” choices are more elastic than they would be in a multinomial logit model.

Figure 9.2 Nested Logit Mode Choice Structure

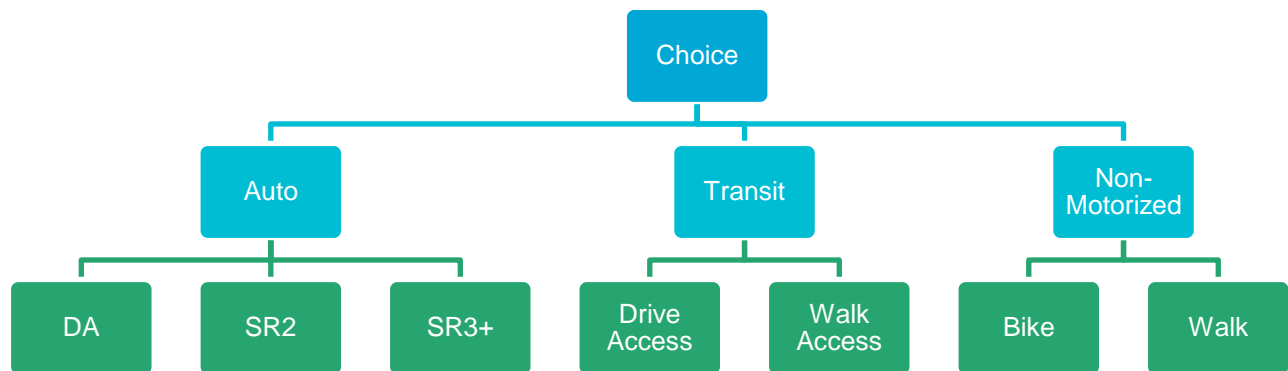

The nested logit model employs several multinomial logit models. The first is choice among primary modes: auto, transit, and non-motorized. The second choice is among sub-modes of the chosen primary mode. That is, if the chosen primary mode was auto, the second choice would be between drive alone, shared ride 2 and shared ride 3+; if the chosen primary mode was transit, the second choice would be between walk and drive access to transit; if the chosen primary mode was non-motorized, the second choice would be between walk and bike.

In application, utilities are calculated at the bottom levels first and passed up through the nesting structure. When this is complete, the probabilities are estimated from the top of the structure down. Composite utilities are passed upward using “logsum” variables.

9.2.1 Market Segmentation

The RMS Model utilizes market segmentation to more accurately model transit ridership. Market segmentation by walk access and egress distance is used to provide a finer level of detail in the walk to

transit modes. Market segmentation by income is used to more accurately identify potential transit riders, as the household travel survey indicated members of low-income households are more likely to use transit. Segmentation of markets into three walk access categories and three walk egress categories results in nine walk access/egress markets demonstrated in **Table 9.5**. The mode choice models are applied once for each of these markets.

Segmentation by walk access provides improved model sensitivity to density and transit oriented developments. This can be illustrated by the application of a mode choice model to a 1 square-mile zone with dense development and access to transit along one edge. Without market segmentation, all residents in the zone would be assumed to have access to transit with a ½ mile walk access resulting in minimal transit ridership in this zone. With market segmentation, some residents would be assumed to have very short walk access lengths, some medium access lengths, and the remainder long (over ¾ mile) access lengths. This scenario results in more realistic representation of actual conditions. A similar example could be applied to walk egress market segmentation.

Table 9.5 Walk Access and Egress Market Segments

Access/Egress	Short Egress	Medium Egress	Long Egress
Short Access	1	2	3
Medium Access	4	5	6
Long Access	7	8	9

Note: Short, medium, and long access and egresses are defined as less than ¼ mile, ¼ to ¾ mile, and more than ¾ mile, respectively.

The first step of the mode choice model calculates for each TAZ the percentage of the area falling within a ¼ mile radius of a transit stop (short access/egress), ¾ mile radius of a transit stop (medium access/egress) and outside of a ¾ mi radius (long access/egress). The transit stations included in this calculation are those belonging to active transit routes. The output from this step looks like the sample in **Table 9.6**. The Activity fields represent a combination of households and employees belonging to each of the access/egress categories. Similarly, the Short, Med, and Long Area fields show the TAZ area belonging to short, medium, and long walk access/egress segments, respectively. The short, medium, and long percentage fields are calculated based on the share of activity in each of the three segments.

Trips in the long walk category are only considered for zone pairs for which transit skims can be built. The skimming procedure uses a maximum walk time of 30 minutes, which equates to a maximum walk distance of 1.25 miles assuming a walk speed of 2.5 mph. The transit modes are not available for the long walk segment in cases where the long walk time exceeds the maximum.

By default, the activity values are apportioned based on TAZ area, resulting in shares apportioned by TAZ area within each market segment. The model features an input table that can be used to override the default calculations. This table has been populated based on a review of aerial photography in selected transit corridors.

This process is also extendable to use sub-TAZ level data (e.g., parcel data) to more accurately define the share of activity in each segment.

Table 9.6 Walk Segments Sample Output

TAZ	Short Activity	Med Activity	Long Activity	Short Pct	Med Pct	High Pct	Short Area	Med Area	Long Area
81	42	0	0	100%	0%	0%	0.03	0.00	0.00
82	0	0	0	33.0%	33.0%	34.0%	0.14	0.15	0.00
83	717	1600	0	30.9%	69.1%	0%	0.20	0.46	0.00
84	28.8	46.5	0.0173	38.2%	61.8%	0%	0.26	0.42	0.00
85	391	98.0	0	79.9%	20.1%	0%	0.10	0.02	0.00
86	684	1.05	0	100%	0%	0%	0.08	0.00	0.00
87	0	13.3	99.2	0%	11.8%	88.2%	0.00	0.08	0.62
88	918	21.6	0	98%	2.30%	0%	0.22	0.01	0.00
89	15.1	93.8	55.4	9.18%	57.1%	33.7%	0.11	0.68	0.40
90	543	0	0	100%	0%	0%	0.18	0.00	0.00

Source: El Paso RMS Model example model run.

9.2.2 Production and Attraction Density Variables

To increase sensitivity of the travel model to transit-oriented development, production and attraction density variables are included in the utility equations. Higher density attraction zones are expected to promote non-SOV modes because of the higher congestion, walkability, and transit service. The density factor is calculated as:

$$Density_i = Ln \left(1 + \frac{POP_i + 2 \times EMP_i}{Area_i} \right)$$

Where:

- POP_i = total population in zone i
- EMP_i = total employment in zone i
- $Area_i$ = area of zone i in acres

9.2.3 Model Specification

The utility equations for the mode choice are documented below. The coefficient designations (e.g., C_{ivtt} for Coefficient of in-vehicle travel time) rather than the actual model coefficients are shown to aid in the understanding of the model specification. The model coefficients are shown in **Table 9.7**. Note that mode choice constants are divided into those that vary by purpose and vehicle sufficiency, and those that vary by purpose and income group. Model constants (K_m) calibrated to reproduce observed mode shares are shown in **Table 9.8** and **Table 9.9**. The vehicle sufficiency constants were estimated and do not vary with mode choice calibration, and are shown in **Table 9.10**. Income and vehicle sufficiency mode constants are added to form the alternative specific constants for each mode.

Drive Alone Utility:

$$\begin{aligned}
 U_{DA} &= K_{Auto} + K_{DA} + C_{IVTT} \cdot IVTT_{drive} \\
 &+ C_{OVTT} \cdot TTIME \\
 &+ C_{Cost(income)} \cdot (CPM \cdot Dist + ParkCost) + K_{DA_Dens} \cdot Density
 \end{aligned}$$

Shared Ride 2 Utility:

$$\begin{aligned}
 U_{SR2} &= K_{Auto} + K_{SR2} + C_{IVTT} \cdot IVTT_{drive} \\
 &+ C_{OVTT} \cdot TTIME \\
 &+ C_{Cost(income)} \cdot \left(\frac{CPM \cdot Dist + ParkCost}{2} \right) + K_{SR2_Dens} \cdot Density
 \end{aligned}$$

Shared Ride 3+ Utility:

$$\begin{aligned}
 U_{SR3} &= K_{Auto} + K_{SR3} + C_{IVTT} \cdot IVTT_{drive} \\
 &+ C_{OVTT} \cdot TTIME \\
 &+ C_{Cost(income)} \cdot \left(\frac{CPM \cdot Dist + ParkCost}{3.2} \right) + K_{SR3_Dens} \cdot Density
 \end{aligned}$$

Note: the cost terms are divided by 2 for SR2 and by 3.2 for SR3+.

Walk to Transit Utilities:

$$\begin{aligned}
 U_{TRW} &= C_{IVTT} \cdot IVTT_{transit} \\
 &+ C_{OVTT} \cdot WalkAccessTime \\
 &+ C_{OVTT} \cdot WalkEgressTime \\
 &+ C_{OVTT} \cdot InitialWaitTime \\
 &+ C_{OVTT} \cdot (XferWalkTime + XferWaitTime + XferPenTime) \\
 &+ C_{Cost(income)} \cdot Fare \\
 &+ K_{TRW_Dens} \cdot Density \\
 &+ K_{TRN} + K_{TRW}
 \end{aligned}$$

Drive to Transit Utilities:

$$\begin{aligned}
 U_{TRD} &= C_{IVTT} \cdot IVTT_{transit} \\
 &+ C_{OVTT} \cdot DriveAccessTime \\
 &+ C_{OVTT} \cdot WalkEgressTime \\
 &+ C_{OVTT} \cdot InitialWaitTime \\
 &+ C_{OVTT} \cdot (XferWalkTime + XferWaitTime + XferPenTime) \\
 &+ C_{OVTT} \cdot TTIME_P \\
 &+ C_{Cost(income)} \cdot Fare \\
 &+ C_{Cost(income)} \cdot CPM \cdot AccessDriveDistance \\
 &+ K_{TRD_Dens} \cdot Density \\
 &+ K_{TRN} + K_{TRD}
 \end{aligned}$$

Walk Utility:

$$U_{Walk} = C_{WALK} \cdot WALKDist + K_{NM} + K_{WALK} + K_{WALK_Dens} \cdot Density$$

Bike Utility:

$$U_{Bike} = C_{BIKE} \cdot IMP_{bike} + K_{NM} + K_{BIKE} + K_{BIKE_Dens} \cdot Density$$

Where:

- IVTT_{transit}* = Transit in-vehicle travel time
- IVTT_{drive}* = Drive in-vehicle travel time
- TTIME* = Terminal time in minutes
- TTIME_P* = Terminal time in minutes (production end only)
- CPM* = Auto operating cost per mile in cents (Set to \$0.13 per mile)
- Dist* = Distance traveled in miles
- ParkCost* = Parking cost (dollars)
- AccessTime* = Walk or drive access time
- EgressTime* = Walk egress time
- InitialWaitTime* = Initial wait time for transit in minutes
- XferWalkTime* = Transfer walk time in minutes
- XferWaitTime* = Transfer wait time in minutes (1/2 of the headway of the route being boarded)
- XferPenTime* = Transfer penalty time in minutes
- Fare* = Transit fare in dollars (average rate paid by all riders)
- WALKDIST* = Walk Distance
- IMP_{bike}* = Bike impedance, weighted by bicycle facility type
- C_x* = Coefficient for variable “x”
- K_{mode}* = Constant for specified mode

Table 9.7 Mode Choice Model Coefficients

Coefficient	HBW	HNW	NHB
In-Vehicle Travel Time (IVTT)	-0.0267	-0.0178	-0.0133
Out of Vehicle Travel Time (OVTT)	-0.0667	-0.0444	-0.0333
Cost (low income)	-0.5079	-0.5079	-0.1581
Cost (med-low income)	-0.3048	-0.3048	-0.1581
Cost (med income)	-0.2111	-0.2111	-0.1581
Cost (med-high income)	-0.1385	-0.1385	-0.1581
Cost (high income)	-0.0693	-0.0693	-0.1581
Walk Distance	-1.7394	-1.5308	-2.2937
Bike Impedance	-0.3302	-0.4231	-0.1876
Nesting Coefficient (Theta)	0.75	0.75	0.75

Table 9.8 Peak Mode Choice Model Constants by Income

Purpose	Auto	DA	SR2	SR3+	TRN	TRD	TRW	NM	BIKE	WALK
HBW (low inc)	2.7009	0	0.6626	-1.8433	1.6292	-1.148	0	0	-4.0064	0
HBW (med-low inc)	0.9506	0	0.6626	-1.8433	-0.7347	-1.7034	0	0	-4.0064	0
HBW (med inc)	3.6999	0	0.6626	-1.8433	-1.3598	-0.3309	0	0	-4.0064	0
HBW (med-high inc)	3.6999	0	0.6626	-1.8433	-1.3598	-0.3309	0	0	-4.0064	0
HBW (high inc)	3.6999	0	0.6626	-1.8433	-1.3598	-0.3309	0	0	-4.0064	0
HNWE1 (low inc)	-0.8711	0	0.382	1.1881	-3.3298	-1.5074	0	0	-2.3509	0
HNWE1 (med-low inc)	-1.2707	0	0.382	1.1881	-5.7687	-1.1813	0	0	-2.3509	0
HNWE1 (med inc)	-0.3712	0	0.382	1.1881	-7.664	-2.644	0	0	-2.3509	0
HNWE1 (med-high inc)	-0.3712	0	0.382	1.1881	-7.664	-2.644	0	0	-2.3509	0
HNWE1 (high inc)	-0.3712	0	0.382	1.1881	-7.664	-2.644	0	0	-2.3509	0
HNWE2 (low inc)	0.0507	0	-1.6418	-2.6325	-0.7215	-0.2065	0	0	-1.9151	0
HNWE2 (med-low inc)	2.0024	0	-1.6418	-2.6325	-2.0335	1.1591	0	0	-1.9151	0
HNWE2 (med inc)	-1.7786	0	-1.6418	-2.6325	-6.4932	-0.7865	0	0	-1.9151	0
HNWE2 (med-high inc)	-1.7786	0	-1.6418	-2.6325	-6.4932	-0.7865	0	0	-1.9151	0
HNWE2 (high inc)	-1.7786	0	-1.6418	-2.6325	-6.4932	-0.7865	0	0	-1.9151	0
HNWR (low inc)	1.0638	0	-0.535	-0.4338	0.1362	-0.6889	0	0	-1.5194	0
HNWR (med-low inc)	-0.3657	0	-0.535	-0.4338	-3.9227	-2.6137	0	0	-1.5194	0
HNWR (med inc)	1.5024	0	-0.535	-0.4338	-5.9768	-1.799	0	0	-1.5194	0
HNWR (med-high inc)	1.5024	0	-0.535	-0.4338	-5.9768	-1.799	0	0	-1.5194	0
HNWR (high inc)	1.5024	0	-0.535	-0.4338	-5.9768	-1.799	0	0	-1.5194	0
HNWO (low inc)	-0.6731	0	-0.5473	-0.2671	-1.7798	-1.0443	0	0	-2.7466	0
HNWO (med-low inc)	-2.0885	0	-0.5473	-0.2671	-5.3786	-1.032	0	0	-2.7466	0
HNWO (med inc)	-1.1483	0	-0.5473	-0.2671	-8.1118	-2.6849	0	0	-2.7466	0
HNWO (med-high inc)	-1.1483	0	-0.5473	-0.2671	-8.1118	-2.6849	0	0	-2.7466	0
HNWO (high inc)	-1.1483	0	-0.5473	-0.2671	-8.1118	-2.6849	0	0	-2.7466	0
NHBW	8.5882	0	-2.1574	-3.4889	-7.0236	0.1668	0	0	1.8951	0
NHBO	11.361	0	0.0295	-0.2936	-2.5416	-0.3999	0	0	3.533	0

Table 9.9 Off-peak Mode Choice Model Constants by Income

Purpose	Auto	DA	SR2	SR3+	TRN	TRD	TRW	NM	BIKE	WALK
HBW (low inc)	2.5648	0	0.686	-1.8386	2.1151	-1.769	0	0	-3.9512	0
HBW (med-low inc)	0.7665	0	0.686	-1.8386	-0.7458	-2.1	0	0	-3.9512	0
HBW (med inc)	3.4924	0	0.686	-1.8386	-1.8392	-0.851	0	0	-3.9512	0
HBW (med-high inc)	3.4924	0	0.686	-1.8386	-1.8392	-0.851	0	0	-3.9512	0
HBW (high inc)	3.4924	0	0.686	-1.8386	-1.8392	-0.851	0	0	-3.9512	0
HNWE1 (low inc)	-1.4162	0	0.3632	1.1722	-1.4519	-0.2372	0	0	-2.3441	0
HNWE1 (med-low inc)	-1.8467	0	0.3632	1.1722	-4.2251	-2.9211	0	0	-2.3441	0
HNWE1 (med inc)	-0.9382	0	0.3632	1.1722	-9.4885	1.7909	0	0	-2.3441	0
HNWE1 (med-high inc)	-0.9382	0	0.3632	1.1722	-9.4885	1.7909	0	0	-2.3441	0
HNWE1 (high inc)	-0.9382	0	0.3632	1.1722	-9.4885	1.7909	0	0	-2.3441	0
HNWE2 (low inc)	0.1338	0	-1.6429	-2.6357	-0.8077	0.0521	0	0	-1.879	0
HNWE2 (med-low inc)	1.5169	0	-1.6429	-2.6357	-1.0503	-0.4355	0	0	-1.879	0
HNWE2 (med inc)	-2.2994	0	-1.6429	-2.6357	-7.0828	-1.2023	0	0	-1.879	0
HNWE2 (med-high inc)	-2.2994	0	-1.6429	-2.6357	-7.0828	-1.2023	0	0	-1.879	0
HNWE2 (high inc)	-2.2994	0	-1.6429	-2.6357	-7.0828	-1.2023	0	0	-1.879	0
HNWR (low inc)	1.2242	0	-0.5399	-0.4426	-0.4147	-0.672	0	0	-1.5394	0
HNWR (med-low inc)	-0.2608	0	-0.5399	-0.4426	-4.0258	-1.5744	0	0	-1.5394	0
HNWR (med inc)	1.6234	0	-0.5399	-0.4426	-5.7075	-2.5672	0	0	-1.5394	0
HNWR (med-high inc)	1.6234	0	-0.5399	-0.4426	-5.7075	-2.5672	0	0	-1.5394	0
HNWR (high inc)	1.6234	0	-0.5399	-0.4426	-5.7075	-2.5672	0	0	-1.5394	0
HNWO (low inc)	-0.7396	0	-0.5469	-0.2649	-1.4957	-1.3916	0	0	-2.7165	0
HNWO (med-low inc)	-2.1473	0	-0.5469	-0.2649	-5.3636	-1.1845	0	0	-2.7165	0
HNWO (med inc)	-1.2118	0	-0.5469	-0.2649	-7.2205	-0.3875	0	0	-2.7165	0
HNWO (med-high inc)	-1.2118	0	-0.5469	-0.2649	-7.2205	-0.3875	0	0	-2.7165	0
HNWO (high inc)	-1.2118	0	-0.5469	-0.2649	-7.2205	-0.3875	0	0	-2.7165	0
NHBW	8.2627	0	-2.1565	-3.4876	-4.5894	-2.1064	0	0	1.8688	0
NHBO	10.910	0	0.0303	-0.2924	-0.9212	-2.0009	0	0	3.5196	0

Table 9.10 Mode Choice Model Constants by Vehicle Sufficiency

Purpose	Auto	DA	SR2	SR3+	TRN	TRD	TRW	NM	BIKE	WALK
HBW (no auto)	0	0	0.	0	0	0	0	0	0	0
HBW (auto < workers)	0	0	-3.7749	-2.2173	-9.3434	0	0	0	0	0
HBW (auto ≥ workers)	0	0	-3.7749	-2.2173	-9.3434	0	0	0	0	0
HNWE1 (no auto)	0	0	0.	0	0	0	0	0	0	0
HNWE1 (auto < workers)	0	0	0.3348	-0.1369	-4.6588	0	0	0	-1.2496	0
HNWE1 (auto ≥ workers)	0	0	0.3348	-0.1369	-4.6588	0	0	0	-1.2496	0
HNWE2 (no auto)	0	0	0.	0	0	0	0	0	0	0
HNWE2 (auto < workers)	0	0	0.3348	-0.1369	-4.6588	0	0	0	-1.2496	0
HNWE2 (auto ≥ workers)	0	0	0.3348	-0.1369	-4.6588	0	0	0	-1.2496	0
HNWR (no auto)	0	0	0.	0	0	0	0	0	0	0
HNWR (auto < workers)	0	0	0.3348	-0.1369	-4.6588	0	0	0	-1.2496	0
HNWR (auto ≥ workers)	0	0	0.3348	-0.1369	-4.6588	0	0	0	-1.2496	0
HNWO (no auto)	0	0	0.	0	0	0	0	0	0	0
HNWO (auto < workers)	0	0	0.3348	-0.1369	-4.6588	0	0	0	-1.2496	0
HNWO (auto ≥ workers)	0	0	0.3348	-0.1369	-4.6588	0	0	0	-1.2496	0
NHBW	0	0	0.	0	0	0	0	0	0	0
NHBO	0	0	0.	0	0	0	0	0	0	0

9.2.4 Auto Occupancy

Once person trips have been separated into the different available modes, it is necessary to convert person trips in vehicles to vehicle trips. This is accomplished through use of an auto occupancy factor. Each drive alone person trip is equivalent to one vehicle trip, and every two SR2 person trips are equivalent to a vehicle trip. Average auto occupancy for SR3+ trips is assumed to be 3.2.

10.0 Trip Assignment

Trip assignment is the final phase of the four-step travel model. Trip assignment includes a process where person trips in vehicles from mode choice are converted into directional vehicle trips by time of day, followed by identification of specific paths taken by vehicle and transit trips. The resulting traffic volumes and transit boarding data are available for four time period as well as a 24-hour period. Due to limited data, trips made using non-motorized modes are not assigned to the network.

When the model is run with speed feedback enabled, travel times resulting from traffic assignment are fed back to trip distribution. The model is then run iteratively until speeds input to trip distribution are reasonably consistent with speeds resulting from traffic assignment.

The traffic and transit assignment procedures in this version of the model remain relatively unchanged from the Destino model. Some roadway capacities have been updated, and volume delay function parameters have been revised.

10.1 Time of Day

10.1.1 Time Period Definitions

The time period definitions have been retained from the Destino model, and are shown in **Table 10.1**.

Table 10.1 Travel Model Time Periods

Period Name	Time Period	Description
AM	7:00 AM – 10:00 AM	AM Peak Period
PM	3:30 PM – 7:30 PM	PM Peak Period
MD	10:00 AM – 3:30 PM	Mid-Day Period
NT	7:30 PM – 7:00 AM	Night-Time Period

Source: Destino Travel Model, reviewed and retained for use in the RMS Model.

10.1.2 Directional Time of Day Factors

The RMS Model uses directional time of day factors to convert trips from production-attraction (PA) format to origin-destination (OD) format and into four time periods. This process is based on data from the household travel survey indicating that trips are made directionally by time of day. For example, HBW trips generally occur from the production to the attraction (i.e., from home to work) in the AM peak and from the attraction to the production (i.e., from work to home) in the PM peak. It is also recognized some trips are made in the reverse of this pattern and many trips are made outside of peak periods, so the factors represent this activity as well as the predominant movements.

In the travel model, time of day factors are applied directly to purpose-specific vehicle trip tables created by the mode choice model. As described in the **Section 7.1**, daily trip tables are separated into peak period (combined AM and PM peak periods) and off-peak (combined mid-day and off-peak) period trips during trip distribution. The traffic assignment time of day module further separates peak period trips into AM and PM peak period trips and off-peak trips into mid-day trips and other off-peak trips. During this conversion, trip

tables are also converted from PA format to OD format. Peak period trips are then separated into sub-periods later in the process.

Time of day factors shown in **Table 10.2** identify the portion of trips by purpose and direction assigned to each time period. These detailed factors are based on the household travel survey, as traffic count data does not contain the trip purpose and direction information necessary to develop this table.

An earlier model step separates peak and off-peak trip tables from trip generation into peak and off-peak trip tables using factors defined in **Table 7.1**. Consequently, all AM and PM factors for each purpose sum to 1, as do MD and NT factors for each purpose. Because truck trips and IE/EI trips are not converted from PA to OD in this step, a single factor is provided for each period.

Table 10.2 Pre-Assignment Directional Time of Day Factors

Purpose	AM		PM		MD		NT	
	P to A	A to P	P to A	A to P	P to A	A to P	P to A	A to P
HBW	0.4391	0.0100	0.0598	0.4911	0.298	0.1597	0.2443	0.298
HNWE1	0.4417	0.0878	0.0903	0.3802	0.3852	0.377	0.086	0.1518
HNWE2	0.4463	0.0197	0.1518	0.3822	0.3787	0.3392	0.0508	0.2313
HNWR	0.0764	0.0411	0.3781	0.5043	0.3072	0.3134	0.116	0.2634
HNWO	0.2677	0.0512	0.2846	0.3965	0.2857	0.2413	0.1537	0.3193
NHB	0.1795	0.1799	0.3219	0.3188	0.3942	0.4108	0.1188	0.0762
LT	0.5567		0.4433		0.8973		0.1027	
HT	0.5567		0.4433		0.8973		0.1027	
IE/EI	0.4546		0.5454		0.8888		0.1112	
THRU	0.2273	0.2273	0.2727	0.2727	0.4444	0.4444	0.0556	0.0556

Source: Destino Travel Model, reviewed and retained for use in the RMS Model.

10.2 Traffic Assignment

The traffic assignment module loads the travel demand represented by the time of day vehicle trip tables onto the roadway network. The RMS Model assigns traffic with user equilibrium assignment, which minimizes travel time for all vehicle trips assigned to the network. This is an iterative assignment algorithm that calculates congested travel time as a function of link volume and shifts travelers to the shortest path. As a result, user equilibrium traffic assignment represents traffic diversion from congested links.

10.2.1 Closure Criteria

After each iteration, the user equilibrium traffic assignment algorithm computes a relative gap corresponding to the difference between the previous and current iteration volumes. The algorithm stops when a pre-selected relative gap is achieved, indicating the network has reached equilibrium and users have found their optimal paths. The relative gap parameter is set to 0.0001 for the RMS Model, which provides a sufficient level of convergence for most model applications. Users may elect to specify a higher convergence criterion for specific applications if oscillations between equilibrium iterations result in unstable assignment results. The gap setting may need adjustment for applications where two very similar model runs (e.g., with only one

small adjustment to the roadway network) produce non-intuitive results. There also may be cases when the network is extremely congested and the specified relative gap cannot be reached within a reasonable amount of time. This is addressed by an iteration limit of 500 set for the RMS Model. As with the gap criterion, the iteration limit can be adjusted if needed during model application. A test run with 2050 demographics on the base year network showed that assignment reaches the specified gap of 0.0001 prior to reaching the 500 iteration limit. For the base year, convergence was achieved in 48 iterations, with a maximum flow change of 79.

10.2.2 Impedance Calculations

The impedance used for determining the shortest path in the traffic assignment model includes travel time and tolls. When including variables in addition to travel time, a generalized cost function converts all variables to a consistent cost using a value of time, as demonstrated in the equation below.

$$\text{Generalized Cost} = \text{Time} * \text{Value Of Time} + \text{Toll Cost}$$

The base year model does not have any tolls in the network, so toll cost is zero.

10.2.3 Volume-Delay Functions

A volume-delay function represents the effect of increasing traffic volume on link travel time in the assignment process. While several volume delay functions are available for consideration, the most commonly used function is the modified Bureau of Public Roads (BPR) function. The modified BPR function is based on the original BPR equation shown below.

$$T_c = T_f \left(1 + \alpha \left(\frac{V}{C} \right)^\beta \right)$$

Where:

T_c	= Congested travel time
T_f	= Freeflow travel time
V	= Traffic volume
C	= Highway design capacity (i.e., upper limit level of service C capacity)
α	= Coefficient alpha (0.15)
β	= Exponent beta (4.0)

The modified BPR equation uses the same form, but replaces design capacity with ultimate (i.e., upper limit LOS E) capacity. The modified function also replaces the coefficient alpha and the exponent beta with calibrated values that vary by functional class and area type. Alpha and beta values in the RMS Model are shown in **Table 10.3**. Alpha and beta values were developed by monitoring link speed and VMT balance by functional class during the model validation process. Alpha and beta for centroid connectors are left at the default BPR values, as centroid connectors are set with very high capacities of 10,000 vehicles per hour. This prevents the model from showing significant congestion on centroid connectors.

Table 10.3 Volume Delay Function Lookup Table (Alpha / Beta)

	Functional Class	CBD (1)	CBD Fringe (2)	Urban (3)	Suburban (4)	Rural (5)
0	Centroid Connector	0.15 / 4.00	0.15 / 4.00	0.15 / 4.00	0.15 / 4.00	0.15 / 4.00
1	Freeway	1.20 / 5.20	1.20 / 5.20	1.20 / 5.20	1.20 / 5.20	1.20 / 5.20
2	Expressway	1.20 / 5.20	1.20 / 5.20	1.20 / 5.20	1.20 / 5.20	1.20 / 5.20
3	Principal Arterial	0.64 / 1.92	0.64 / 1.92	0.64 / 1.92	0.64 / 1.92	0.64 / 1.92
4	Minor Arterial	0.45 / 1.92	0.45 / 1.92	0.45 / 1.92	0.45 / 1.92	0.45 / 1.92
5	Collector	0.35 / 1.73	0.35 / 1.73	0.35 / 1.73	0.35 / 1.73	0.35 / 1.73
7	Local	0.35 / 1.73	0.35 / 1.73	0.35 / 1.73	0.35 / 1.73	0.35 / 1.73
20	Ramp	0.64 / 1.92	0.64 / 1.92	0.64 / 1.92	0.64 / 1.92	0.64 / 1.92
51	Transit Only	n/a	n/a	n/a	n/a	n/a
61	Non-Motorized	n/a	n/a	n/a	n/a	n/a

Source: Destino Travel Model, reviewed and updated for use in the RMS Model.

10.2.4 Multi-Class Assignment

The RMS Model considers 14 different vehicles classes in the traffic assignment step: single occupant vehicles (by income group for HBW trips and a single class for non-work trips), shared ride 2 vehicles, shared ride 3+ vehicles, light trucks, medium trucks, heavy trucks, external internal auto trips, through auto trips, and through truck trips. The RMS Model does not assign transit vehicles to the highway network.

In the constrained traffic assignment, the vehicle classes are assigned simultaneously, but with slightly different settings. Some classes are prohibited from using certain links, and different value of time and toll value are permitted. A description of settings applied for each class is included below, with value of time values shown in **Table 10.4**. Values of time are divided by a perception factor of 70% that reflects lower perceived toll values associated with automated toll collection.

After traffic assignment is complete, traffic volumes are available for each individual vehicle class.

- Single Occupant Vehicle: SOVs are excluded from using HOV lanes and can be set to incur toll charges on express lanes or standalone toll facilities.
- Shared Ride 2 Vehicles: These vehicles are excluded from HOV links coded with a minimum occupancy requirement of 3 and can be set to incur toll charges on express lanes or standalone toll facilities.
- Shared Ride 3+ Vehicles: These vehicles can use any roadway link in the network but can still be set to incur tolls on express lanes or standalone toll facilities.
- Trucks: These trucks are excluded from HOV lanes and any link coded with a truck prohibition.

Table 10.4 Perceived Value of Time by Vehicle Class

Vehicle Class	Value of Time (2017\$)
SOV low income	\$3/hour (\$5 cents/min)
SOV med-low income	\$7.5/hour (\$12.5 cents/min)
SOV med income	\$10.8/hour (\$18 cents/min)
SOV med-high income	\$16.5/hour (\$27.5 cents/min)
SOV high income	\$33/hour (\$55 cents/min)
SOV non-work	\$7.2/hour (\$12 cents/min)
Shared Ride 2	\$7.2/hour (\$12 cents/min)
Shared Ride 3+	\$7.2/hour (\$12 cents/min)
Internal Trucks	\$7.2/hour (\$12 cents/min)
External Internal	\$7.2/hour (\$12 cents/min)
External Trucks	\$7.2/hour (\$12 cents/min)
External Auto	\$7.2/hour (\$12 cents/min)

Note: These values of time include a perception factor of 70%.

10.3 Speed Feedback

The trip distribution and mode choice model steps rely on congested zone to zone travel time information to distribute trips and identify mode shares. The traffic assignment step produces estimated congested travel speeds based on traffic flows and application of the volume-delay function. The speeds input to trip distribution and mode choice are generally not consistent with the speeds output from traffic assignment. To rectify this inconsistency, results from the AM traffic assignment are used to re-compute peak zone to zone travel times, and the results from the MD traffic assignment are used to re-compute off-peak zone to zone travel times. The model is re-run, and a comparison is then made between the initial and updated zone to zone travel times, as depicted in **Figure 10.1**. If the travel times are not reasonably similar, the updated travel times are then fed back to trip distribution and mode choice. This process is repeated iteratively until a convergence criterion or iteration limit is met.

Inclusion of a speed feedback process in the travel model can have interesting and desirable effects on the way the travel model represents the effects of network improvements in congested situations. Without speed feedback, overall regional travel demand remains constant regardless of the amount of roadway network congestion because trip distribution and mode choice patterns are not affected by changing congestion levels.

When speed feedback is added to the model, heavy congestion results in slower speeds, thereby leading to shorter trip patterns in areas with heavy congestion. As roadway improvements are added to the model, the associated capacity increase results in faster travel speeds as localized congestion decreases. The higher speeds result in longer trip lengths, which has the effect of incrementally increasing overall vehicle miles traveled. In the mode choice model, slower roadway speeds typically result in slower transit speeds as well, minimizing the effect of speed feedback on transit results. Speed feedback has a more notable effect on transit results when modeling transit options that do not experience speed degradation as traffic congestion increases. Inclusion of speed feedback is most important from a mode choice perspective when using the model to test options such as BRT, rail, or improvements such as transit signal prioritization or queue jumps.

Figure 10.1 Feedback Process

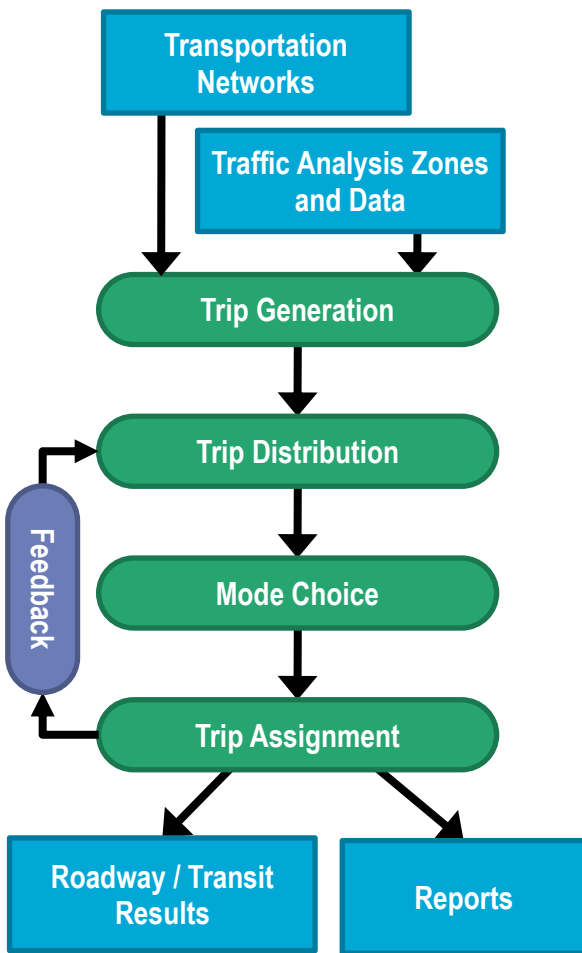

10.3.1 Method of Successive Averages

The simplest approach to speed feedback merely feeds link speeds from traffic assignment back to the trip distribution and mode choice model steps. This approach will often lead to convergence problems as trip distribution oscillates between long and short trip lengths. Instead, the model uses the method of successive averages (MSA) to implement speed feedback. With this approach, volumes resulting from traffic assignment are averaged over multiple iterations. These average volumes are then input to the volume delay equation to compute speeds for use in trip distribution and mode choice.

MSA uses a simple average of all flows resulting from previous assignment runs. MSA flows can be computed as shown in the equations below.

$$MSAFlow_n = \left(MSAFlow_{n-1} - \frac{MSAFlow_{n-1}}{n} \right) + \frac{Flow_n}{n}$$

$$MSAFlow_n = MSAFlow_{n-1} + \frac{1}{n} (Flow_n - MSAFlow_{n-1}) \quad [Simplified]$$

Where:

MSA_{Flow} = Flow calculated using the MSA
 n = current iteration
 $Flow$ = Flow resulting from traffic assignment

The method of successive averages assigns a weight to the traffic volumes from each traffic assignment iteration that is equal to the reciprocal of the iteration number. In other words, the volume results from each previous iteration are weighted equally when computing travel times for trip distribution. After the new MSA-weighted flows are calculated, speeds on each link in the roadway network are re-estimated, and the remainder of the model is run to complete the iteration.

10.3.2 Initial Speeds and Borrowed Feedback Results

Use of the MSA feedback procedure produces results that are sensitive to the initial speeds/travel times input to the first iteration of the trip distribution model. For this reason, caution must be used when comparing results of different model runs that include speed feedback. In cases where different model runs will be compared directly, initial congested speeds should be initialized using free flow speeds when speed feedback model is active.

In some cases, it is desirable to run the model to test multiple alternatives without running speed feedback for each scenario. For these cases, it is possible to run the model once with speed feedback enabled to establish a baseline forecast scenario (e.g., future growth on existing and committed network) and then save the final model results with speed feedback for use in alternative testing runs. The model can then be run using these saved speeds and without running the speed feedback loop. When using this approach, the baseline scenario should be run a second time using the saved speeds and without feedback to ensure consistency between all scenarios.

10.3.3 Convergence Criteria

It is important that a meaningful convergence criterion is specified when running a model with speed feedback. The convergence criterion should be monitored during model runs to prevent unnecessary iterations of the speed feedback process, as the convergence measure will provide diminishing benefits after a certain point. The point at which the best possible convergence has been met will often vary with the level of congestion in a network. Therefore, it is particularly important to monitor speed feedback convergence when first running a dataset that is significantly different than previously considered scenarios.

Traffic assignment convergence settings also affect speed feedback convergence. If traffic assignment does not adequately converge, the speed feedback convergence measure may improve slowly or inconsistently. Alternately, if traffic assignment is set to converge more fully, the speed feedback convergence measure may improve more consistently and more quickly. However, closure settings that are too stringent can result in unreasonably long model run times.

10.3.4 Shortest Path Root Mean Square Error

Shortest Path Root Mean Square Error (% RMSE) is a common way to measure speed feedback convergence. This measure compares zone to zone travel time matrices between subsequent iterations, so %RMSE provides an indication of how similar the two travel time matrices are to one another. This approach directly satisfies the requirement that inputs to trip distribution and outputs from traffic assignment are

reasonably similar. This method also has the advantage of measuring convergence criteria without the need to run traffic assignment for the final iteration. This facilitates a simpler structure for the speed feedback model. The model uses % RMSE to monitor speed feedback convergence using the equation below.

$$\%RMSE = \frac{100 \cdot \sqrt{\sum_z (t_{z(i)} - t_{z(i-1)})^2}}{\frac{\sum_z t_{z(i)}}{n}}$$

Where:

- $\%RMSE$ = Percent Root Mean Square Error
- $t_{z(i)}$ = Travel time for zone pair z for feedback iteration i
- $t_{z(i-1)}$ = Travel time for zone pair z for feedback iteration $i - 1$
- n = Number of zone to zone pairs

Figure 10.2 shows the decrease in peak period %RMSE after every feedback loop or iteration. After the 5th iteration, the %RMSE does not change much indicating that the model stabilizes after 5 iterations. Therefore, the current base year model is set to run through five feedback loops.

Figure 10.2 Peak Period % RMSE by Iteration

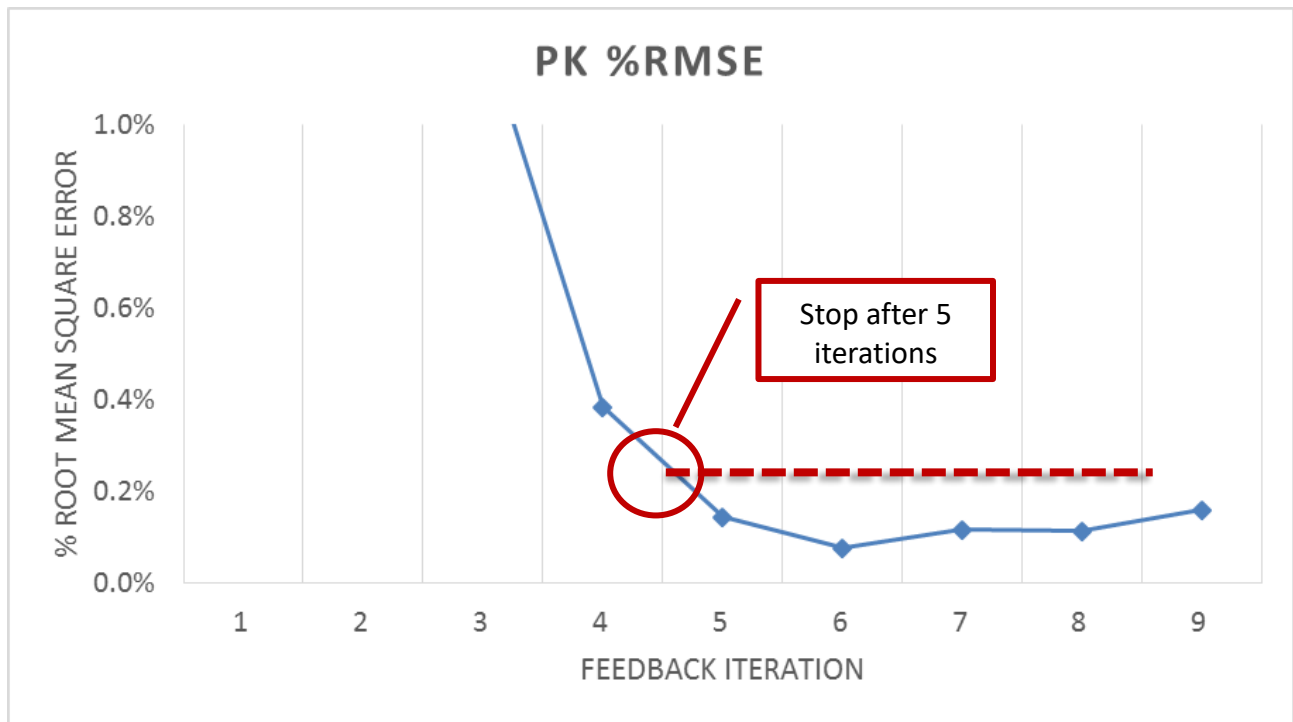

10.3.5 Application of Speed Feedback for Alternatives Analysis

Speed feedback ensures travel time consistency within the entire modeling structure. It was conceived as a model enhancement in the early 1990's largely in response to environmental lawsuits, although it is good practice and now considered a necessity. Generally, speed feedback is most sensitive to network changes that provide a significant travel time improvement. These types of alternatives warrant running the feedback process because they can affect regional travel patterns. Less significant improvements can also affect travel times and regional travel patterns to various degrees and should be considered for feedback.

For all interim milestone and horizon years, speed feedback should be executed. For subsequent alternatives analysis, speed feedback should be considered for any of the conditions listed below. Further information on available speed feedback settings is presented in Section 10.3.2

- A significant new roadway alternative (i.e., new or greatly improved access) would likely warrant speed feedback. This would be true for new or significantly better access to areas that are undeveloped, developing, or already developed. For undeveloped areas, it is likely the effect is more significant in later years. Examples include new freeway interchanges, new freeway lanes, new freeways and arterials, and in limited cases new collector roads.
- Less significant roadway improvements might warrant running speed feedback. These might include roadway widening or corridor improvements that imply functional class, speed, or capacity changes. Improvements limited to a short section of roadway or an intersection generally would not warrant running speed feedback.
- A significant change to socioeconomic assumptions as compared to the base case. Speed feedback is more likely to be necessary when changes cover a large area and involve significant demographic shifts but could conceivably be warranted after changes to a small number of zones with very high activity. Socioeconomic changes should also include an update to area type assumptions.
- Significant changes to external trip or special generator assumptions.
- Any model run in which a significant change in congestion on any corridor is anticipated could affect regional travel times and travel patterns. This criterion is largely covered by those above.
- Changes to model parameters, factors, coefficients, etc. – *Note: These changes should only be made in conjunction with model calibration and validation, but any tests of changes to parameters should include running the feedback process.*

10.4 Transit Assignment

Transit person trips resulting from the mode choice model are assigned to the transit route system. Each trip is assigned from zone centroid to zone centroid using the roadway network (for access and egress) and transit routes. The transit assignment step does not include capacity constraint, so increasing transit volumes do not result in diversion of transit trips to other transit service.

Transit assignment results include the total number of boardings at each transit stop, as well as transit volumes on all stop to stop transit route segments. However, transit results are generally best evaluated at the systemwide or route group level. Individual route, stop, and segment values have not been validated to

observed conditions. Prior to using the model to support detailed transit corridor studies, a focused transit model calibration and validation effort is recommended.

11.0 Calibration and Validation

The RMS Model has been calibrated to match household travel survey data and location-based services data and validated to traffic count and transit boarding data. This section documents the stepwise model calibration and validation process.

11.1 Trip Generation Calibration

Since new households survey data were not available to support this model update, trip rates estimated and calibrated for use in the Destino model served as a starting point for the trip distribution model. Trip rates obtained from the Destino Model were factored so that overall travel model volumes match regional VMT totals. Based on analysis of model validation in areas with high and low income households, higher factors were applied to the highest income groups. Trip rates documented in **Section 6.3** reflect factoring conducted during model calibration.

11.2 Trip Distribution Calibration

11.2.1 Trip Distribution Calibration

The trip distribution model was calibrated by comparing observed and modeled average trip lengths and trip length frequency distributions. Observed trip length frequency distributions (TLFDs) were created using trip tables extracted from household survey data and LBS data. These trip tables were combined with congested shortest path matrices generated by the model. The TLFDs resulting from the two different sources were reasonably similar and served as trip distribution calibration targets.

Trip distribution calibration began with friction factors from the Destino Model. Friction factors were converted from table form to gamma functions, represented by the formula described in **Section 7.2**. These friction factors served as a starting condition for initial application in the RMS model. The initial factors were iteratively adjusted to improve the match between modeled and observed TLFDs. This iterative process was repeated several times, as the shortest path matrices are sensitive to other changes in the model such as network, trip rate, and mode choice adjustments. Shortest path matrices for each trip length calibration exercise were generated using results from a full feedback model run.

Three measures of trip length calibration include average trip travel time, coincidence ratio between the observed and modeled TLFDs, and a visual comparison of the observed and modeled TLFDs. The coincidence ratio, representing the portion of area under both the observed and modeled curves, is a value that can range from zero to one, with one indicating a perfect match. A comparison of coincidence ratios and average daily trip travel times by trip purpose is shown in **Table 11.1**, with trip length frequency distributions for each trip purpose shown in **Figure 11.1** through **Figure 11.6**. Calibration was performed separately for peak and off-peak conditions, with results summed to daily for the statistics shown below.

Table 11.1 Average Daily Travel Times by Trip Purpose

Purpose	Average Trip Travel Time			Coincidence Ratio	
	Modeled	Target (Survey)	Target (LBS)	Survey	LBS
HBW	15.0	14.9	13.2	0.85	0.80
HNWE1	5.5	5.1	-	0.88	-
HNWE2	15.2	14.9	-	0.71	-
HNWR	9.6	9.2	10.7	0.81	0.85
HNWO	11.1	10.6	10.7	0.78	0.84
NHB	9.5	8.7	9.9	0.79	0.82

Source: RMS Model Output Files, 2010-2011 Household Travel Survey, and 2017 LBS Data

Figure 11.1 Home-Based Work Trip Length Frequency Distribution

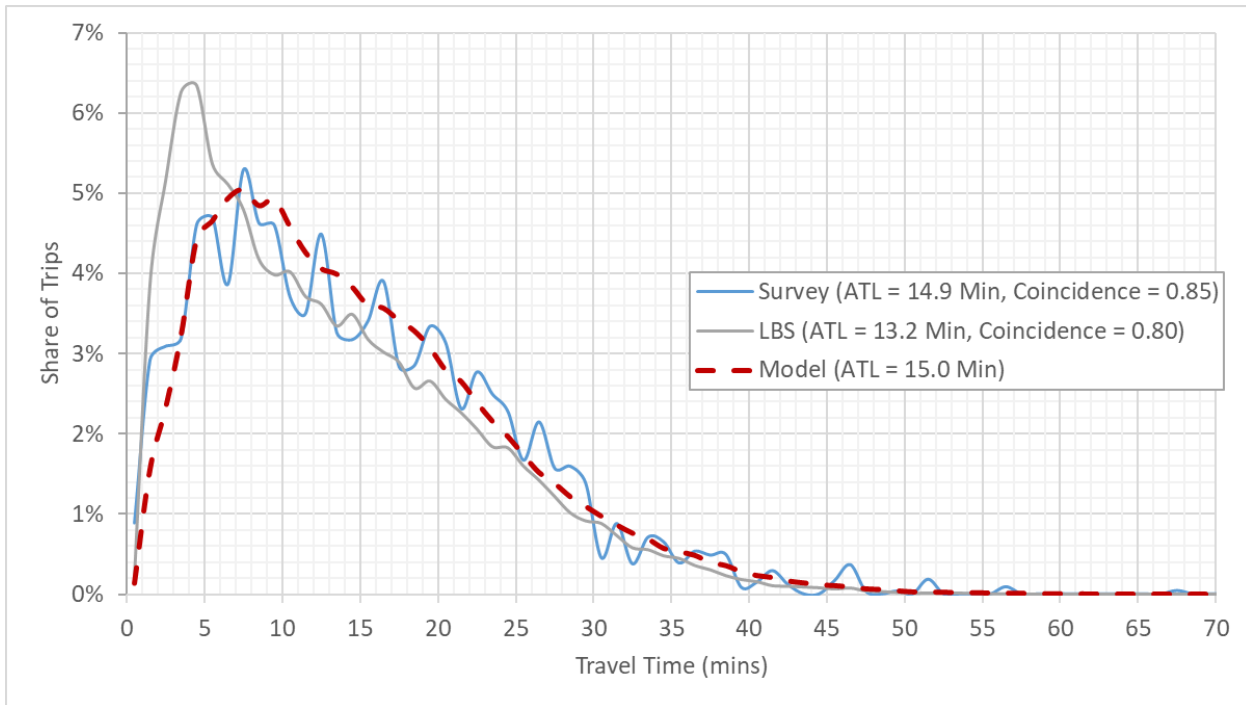

Figure 11.2 Home-Based Non-Work Education 1 Trip Length Frequency Distribution

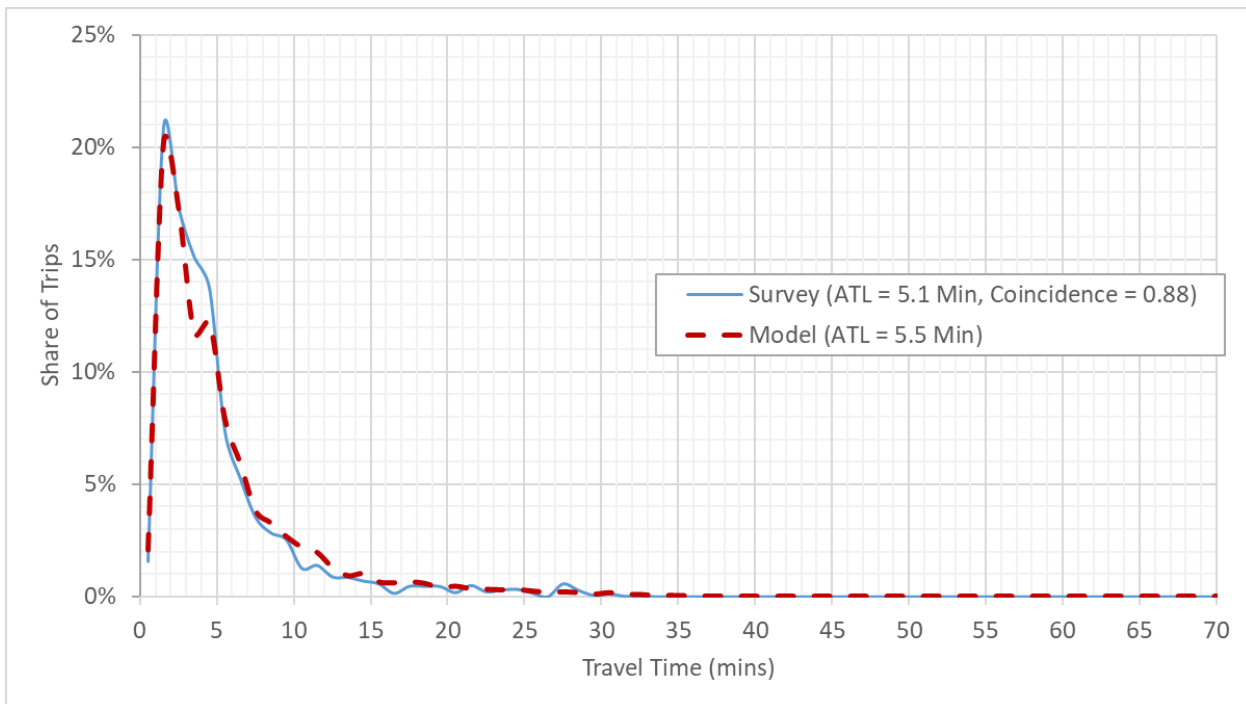

Figure 11.3 Home-Based Non-Work Education 2 Trip Length Frequency Distribution

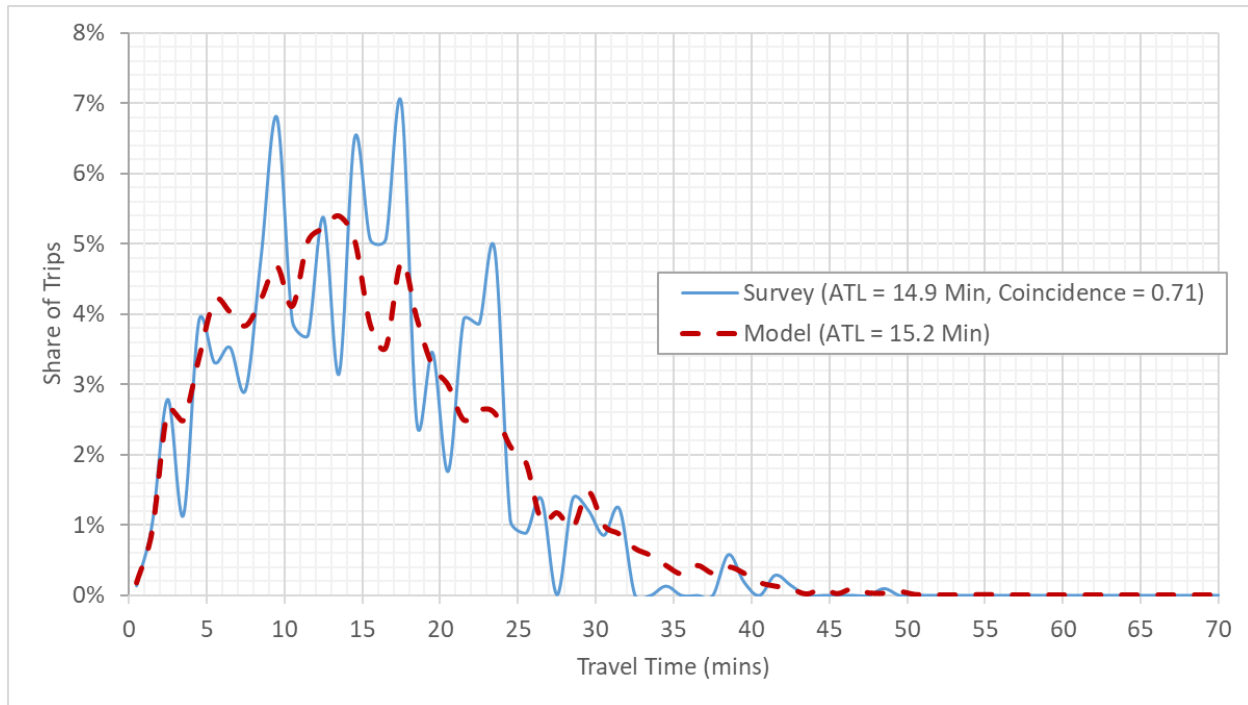

Figure 11.4 Home-Based Non-Work Retail Trip Length Frequency Distribution

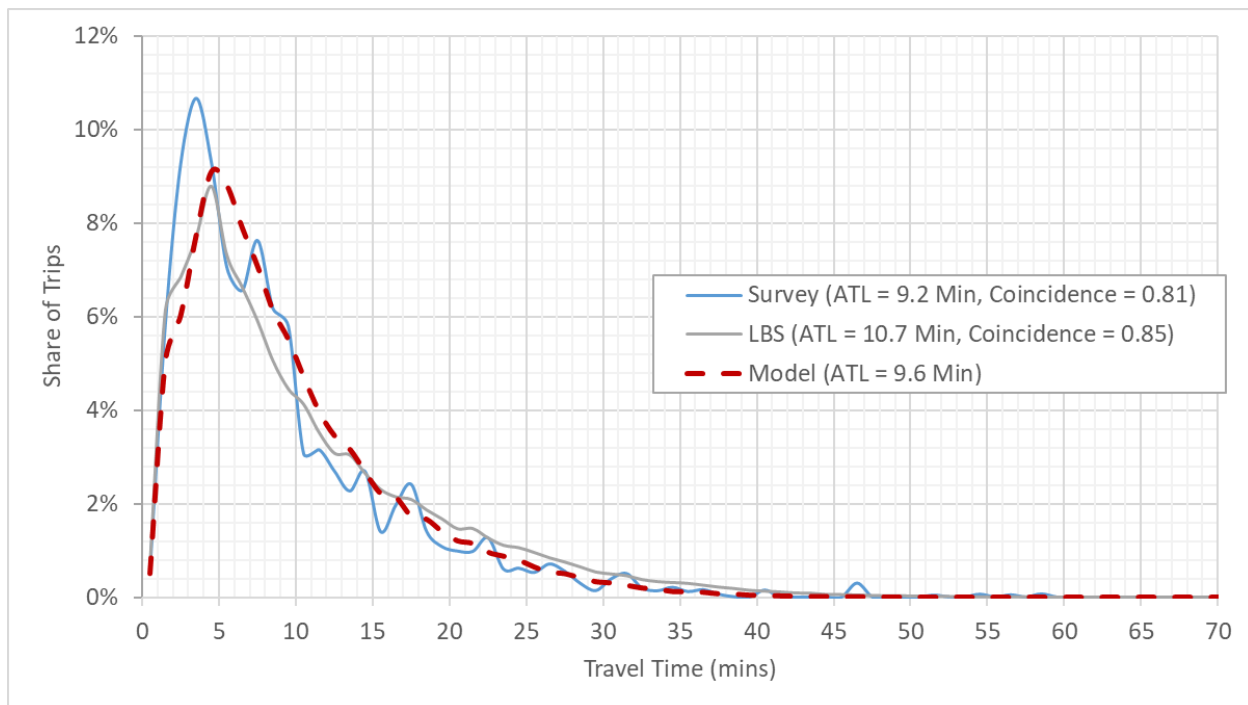

Figure 11.5 Home-Based Non-Work Other Trip Length Frequency Distribution

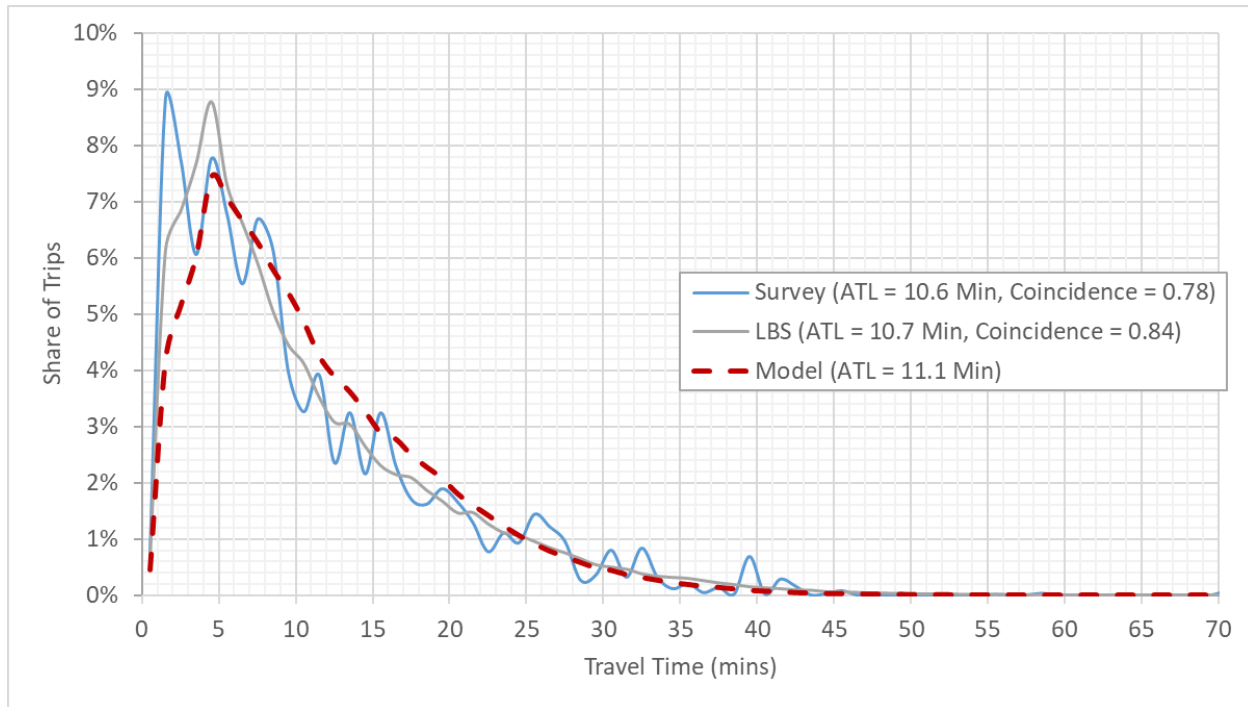
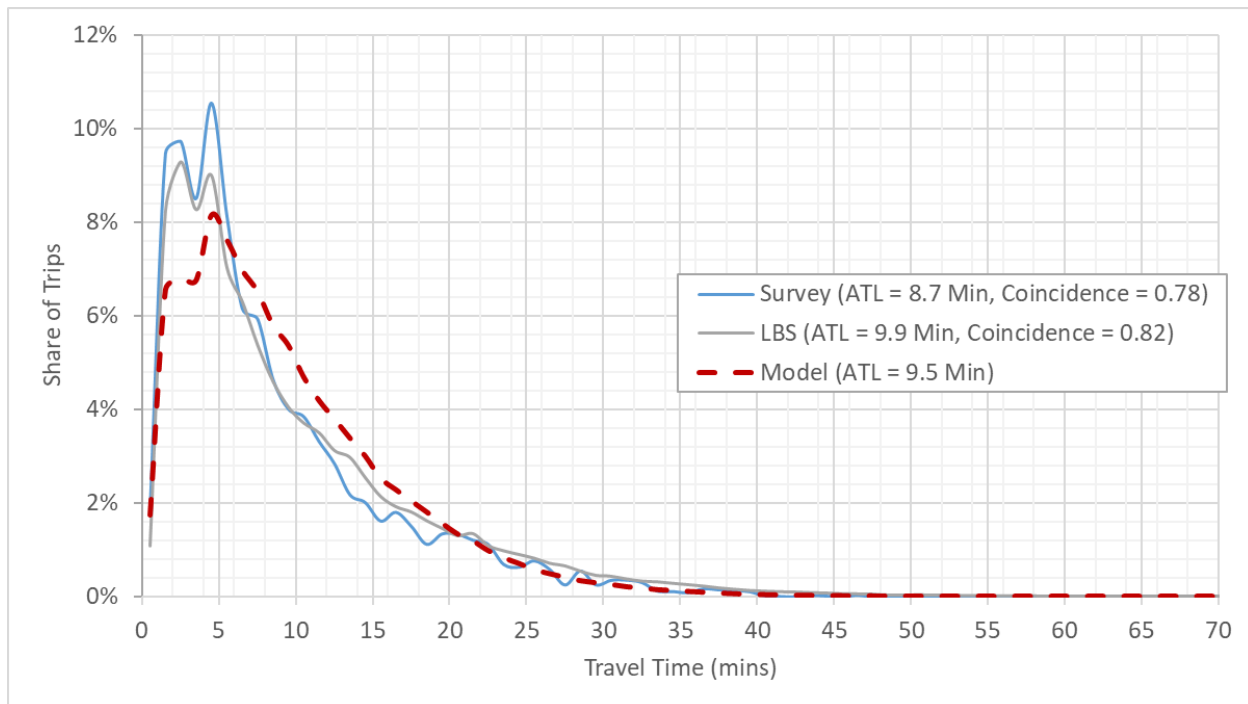

Figure 11.6 Non-Home Based Trip Length Frequency Distribution



11.3 Mode Choice Calibration

The mode choice model has been calibrated to the targets documented in **Section 9.1**. Calibration was performed by iteratively running the mode choice model, and then adjusting ASCs for each mode and

purpose. The RMS Model includes a calibration tool that automatically calibrates mode choice to match a given set of targets. This tool calibrates constants using a tiered approach, considering top-level modes separately from bottom-level modes. This helps avoid over-specification of the model by allowing only certain modes where data are sufficient to be calibrated by income group. For some modes, there are insufficient data or variation to calibrate constants by income. **Figure 11.7** shows which modes and sub-modes in the nested logit structure are calibrated by income, and which are not. A summary of mode choice calibration results is shown in **Table 11.2** through **Table 11.4**.

Figure 11.7 Mode Choice Calibration Methods

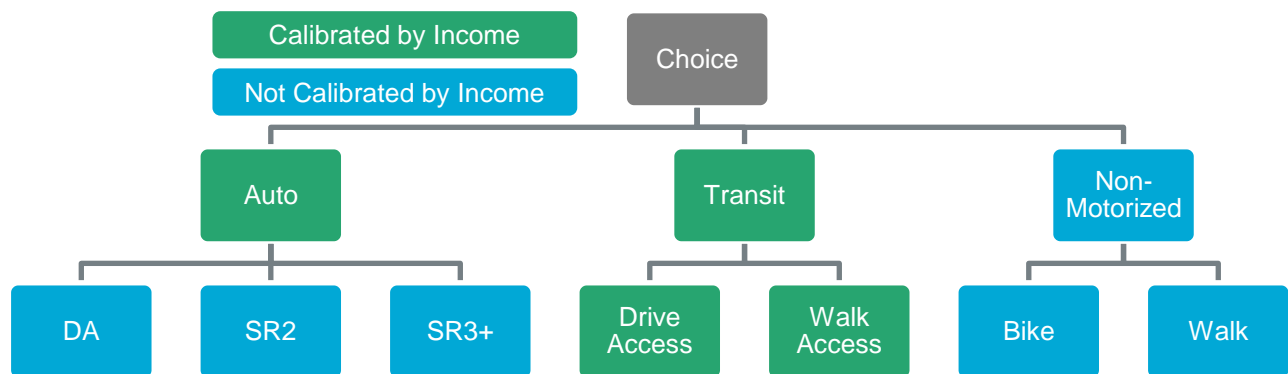

Table 11.2 Mode Choice Calibration Targets – Number of Trips

Purpose	Drive Alone	SR2	SR3	Transit Drive	Transit Walk	Bike	Walk
HBW	506,836	41,742	12,625	309	4,660	651	6,841
HNWE1	91,049	191,145	277,631	106	1,238	4,468	73,844
HNWE2	77,973	24,888	6,289	280	2,989	177	837
HNWR	176,839	158,572	116,165	387	5,337	1,305	6,696
HNWO	166,231	150,464	133,398	378	6,838	1,937	27,956
NHBW	124,419	17,780	5,176	52	1,053	15	2,857
NHBO	184,555	234,208	186,625	232	3,640	515	19,605
All Purposes	1,327,902	818,799	737,908	1,744	25,755	9,068	138,635

Source: Analysis of 2010-2011 Household Survey Data and 2017 Transit Boarding Data

Table 11.3 Mode Choice Model Results – Number of Trips

Purpose	Drive Alone	SR2	SR3	Transit Drive	Transit Walk	Bike	Walk
HBW	507,215	41,759	12,630	307	4,816	665	6,425
HNWE1	90,382	191,387	277,887	106	1,238	4,465	74,017
HNWE2	77,888	24,867	6,294	281	2,935	176	939
HNWR	176,915	158,566	116,167	387	5,359	1,310	6,620
HNWO	166,267	150,423	133,335	377	6,844	1,941	28,019
NHBW	124,527	17,787	5,177	52	1,053	15	2,878
NHBO	184,599	234,143	186,535	231	3,639	516	19,713
All Purposes	1,327,793	818,932	738,025	1,741	25,884	9,088	138,611

Source: RMS Model Output Files

Table 11.4 Mode Choice Calibration Results – Percent Difference

Purpose	Drive Alone	SR2	SR3	Transit Drive	Transit Walk	Bike	Walk
HBW	0.1%	0.0%	0.0%	-0.5%	3.3%	2.2%	-6.1%
HNWE1	-0.7%	0.1%	0.1%	0.4%	0.0%	-0.1%	0.2%
HNWE2	-0.1%	-0.1%	0.1%	0.2%	-1.8%	-0.7%	12.2%
HNWR	0.0%	0.0%	0.0%	0.0%	0.4%	0.4%	-1.1%
HNWO	0.0%	0.0%	0.0%	-0.4%	0.1%	0.2%	0.2%
NHBW	0.1%	0.0%	0.0%	0.5%	0.0%	-0.3%	0.7%
NHBO	0.0%	0.0%	0.0%	-0.2%	0.0%	0.2%	0.6%
All Purposes	0.0%	0.0%	0.0%	-0.1%	0.5%	0.2%	0.0%

Source: RMS Model Output Files, 2010-2011 Household Survey Data, and 2017 Transit Boarding Data

11.4 Traffic Assignment Validation

Traffic assignment validation is the process of comparing modeled traffic volumes to traffic count data. Validation ensures that the model reasonably matches observed traffic patterns in the base year. It uses traffic count data obtained from various sources and placed on the roadway network. Comparisons were made using a variety of techniques, including regional comparisons and inspection of individual link values.

11.4.1 Overall Activity Level

Overall vehicle trip activity was validated by comparing count data to model results on all links where count data is available using two statistics: model volume to count volume ratio and model VMT as compared to count VMT. These statistics were reviewed at functional class, area type, and regional levels, as shown in **Table 11.5**.

Table 11.5 Regional Modeled Volumes and VMT vs. Counts

Link Type	Modeled Volumes/ Counts	Modeled VMT/ Count VMT	Target
Freeways	103.2%	104.4%	+/- 10%
Expressways	100.8%	104.3%	+/- 10%
Principal Arterials	104.5%	100.0%	+/- 10%
Minor Arterials	98.2%	95.3%	+/- 10%
Collectors and Frontage Roads	95.6%	90.1%	+/- 25%
CBD	95.2%	91.7%	n/a
CBD Fringe	106.5%	101.0%	n/a
Urban	104.0%	100.7%	n/a
Suburban	100.2%	98.5%	n/a
Rural	102.1%	99.5%	n/a
Total	101.4%	99.1%	+/- 5%

Source: El Paso RMS Model.

Note: Activity level targets are based on industry standard practice guidelines, not a rule or regulation.

11.4.2 Measures of Error

While the model should accurately represent the overall level of activity, it is also important to verify the model has an acceptable level of error. The model is not expected to perfectly reproduce count volumes on every link, but the level of error should be monitored. The plot shown in **Figure 11.8** demonstrates the ability of the RMS Model to match individual traffic count data points. **Table 11.6** lists RMSE and percent RMSE values along with target values by functional class and area type. General guidelines suggest that percent RMSE should be below 40 percent region-wide, with values near or below 30 percent for high volume facilities such as freeways. The percent RMSE measure tends to over-represent errors on low volume facilities, so values on collectors are not particularly meaningful.

Percent RMSE is expected to be higher on low volume facilities, decreasing as volumes increase.

Table 11.7 show the % RMSE values by volume group, demonstrating low percent RMSE values for high volume facilities.

Figure 11.8 Model Volume/Count Comparison

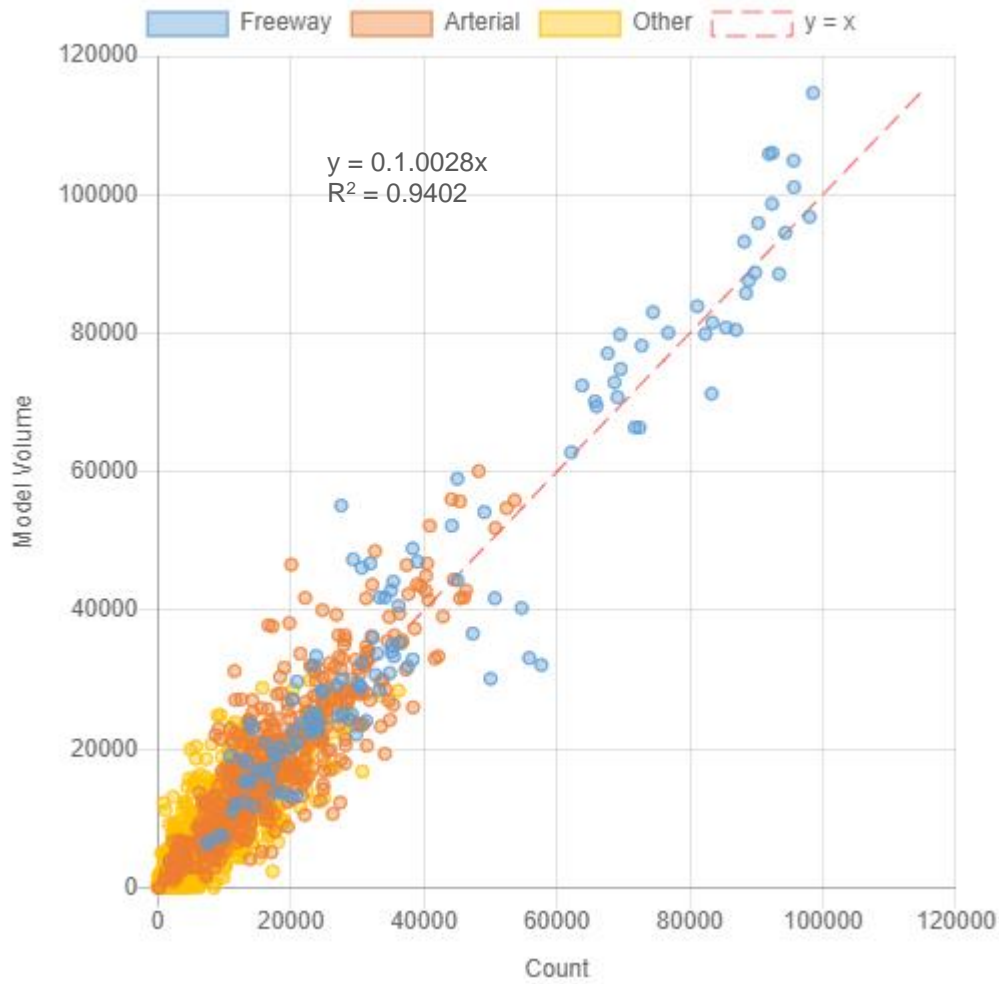

Table 11.6 RMSE Statistics by Link Type

Link Type	RMSE	% RMSE	Target	Number of Links with Counts
Freeways	7,564	18.1%	10-20%	124
Expressways	3,813	31.1%	20-30%	32
Principal Arterials	5,680	32.6%	< 40%	482
Minor Arterials	4,177	46.2%	< 50%	504
Collectors and Frontage Roads	3,733	67.4%		363
CBD	2,893	52.0%	n/a	62
CBD Fringe	3,500	23.6%	n/a	18
Urban	5,908	33.2%	n/a	350
Suburban	4,901	37.1%	n/a	966
Rural	2,466	46.1%	n/a	214
Total	4,819	37.4%	< 40%	1,610

Source: El Paso RMS Model.

Note: RMSE targets are based on industry standard practice guidelines, not a rule or regulation.

Table 11.7 RMSE Statistics, by Volume Group

Volume Group	Links	RMSE	% RMSE
0 - 1,000	158	2,335	116.8%
1,000 - 5,000	396	2,661	66.5%
5,000 - 10,000	332	3,724	46.7%
10,000 - 20,000	383	4,963	35.3%
20,000 - 30,000	201	6,209	28.3%
30,000 - 50,000	95	9,678	29.1%
50,000 - 100,000	40	7,928	11.3%
100,000 and up	5	13,750	14.5%
All Links	1,610	4,819	37.4%

Source: El Paso RMS Model.

11.4.3 Screenline Analysis

The RMS Model includes 16 screenlines, shown in **Figure 11.9**. Screenlines capture distinct regional or inter-regional travel patterns and can be useful in understanding the model's trip generation and trip distribution characteristics. Screenlines have been drawn to cover links that either have observed traffic volumes or are known to carry very low traffic volumes. As demonstrated in **Table 11.8** and **Figure 11.10**, error on each screenline falls within the maximum desirable error as defined in NCHRP Report 255 with most falling below 15%.

Table 11.8 RMS Model Screenline Analysis

Screenline	Model Volume	Observed Volume	% Error
1	78,258	76,330	2.5%
2	365,115	364,784	0.1%
3	294,644	258,800	13.9%
4	136,590	125,000	9.3%
5	139,810	150,550	-7.1%
6	325,029	290,594	11.8%
7	191,998	211,224	-9.1%
8	79,794	78,700	1.4%
9	288,130	295,230	-2.4%
10	142,204	140,967	0.9%
11	47,758	35,990	32.7%
12	158,977	144,750	9.8%
13	115,730	114,720	0.9%
14	160,540	163,986	-2.1%
15	36,306	33,190	9.4%
16	9,961	13,550	-26.5%

Source: El Paso RMS Model.

Figure 11.9 RMS Model Screenlines

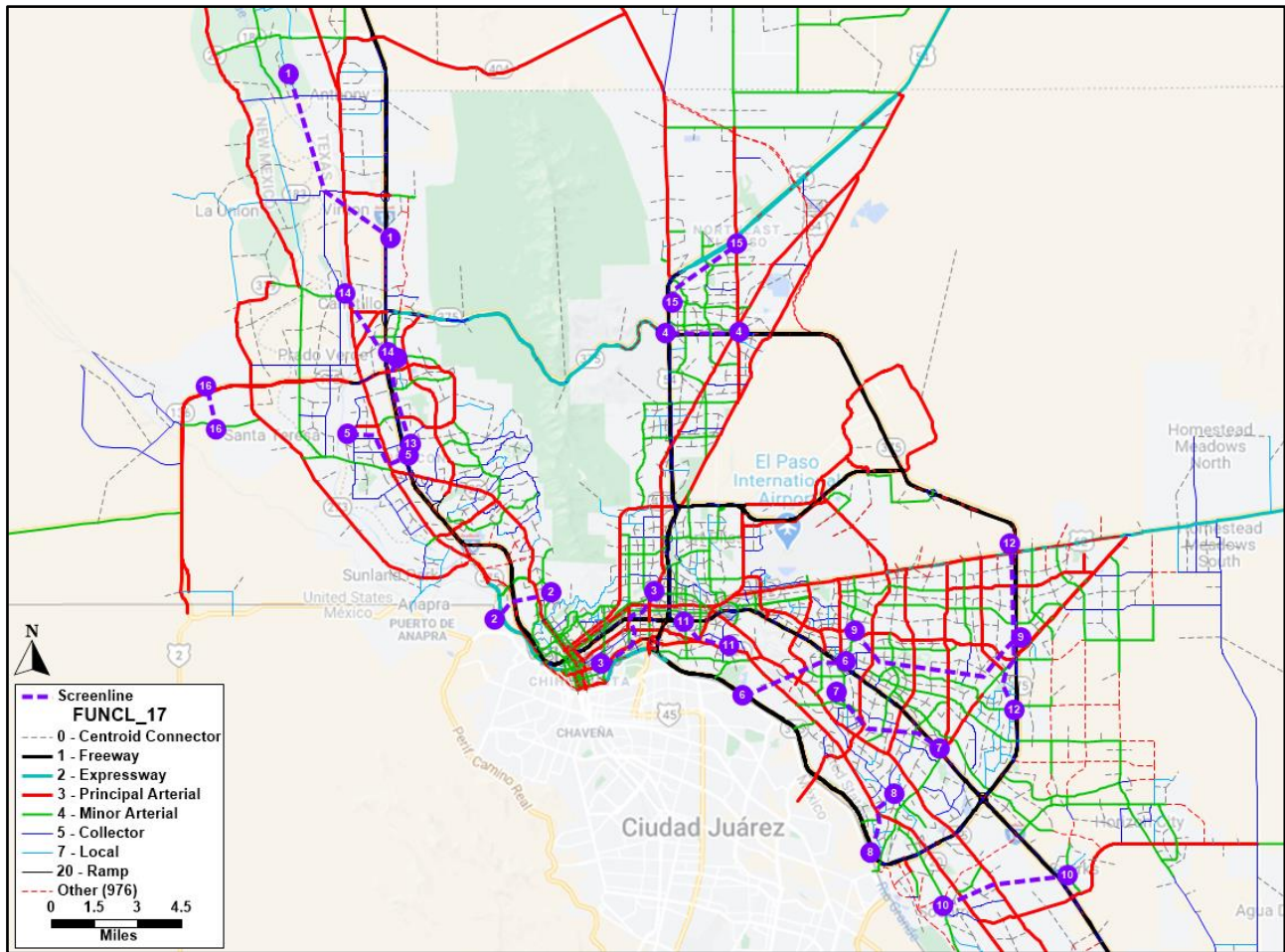
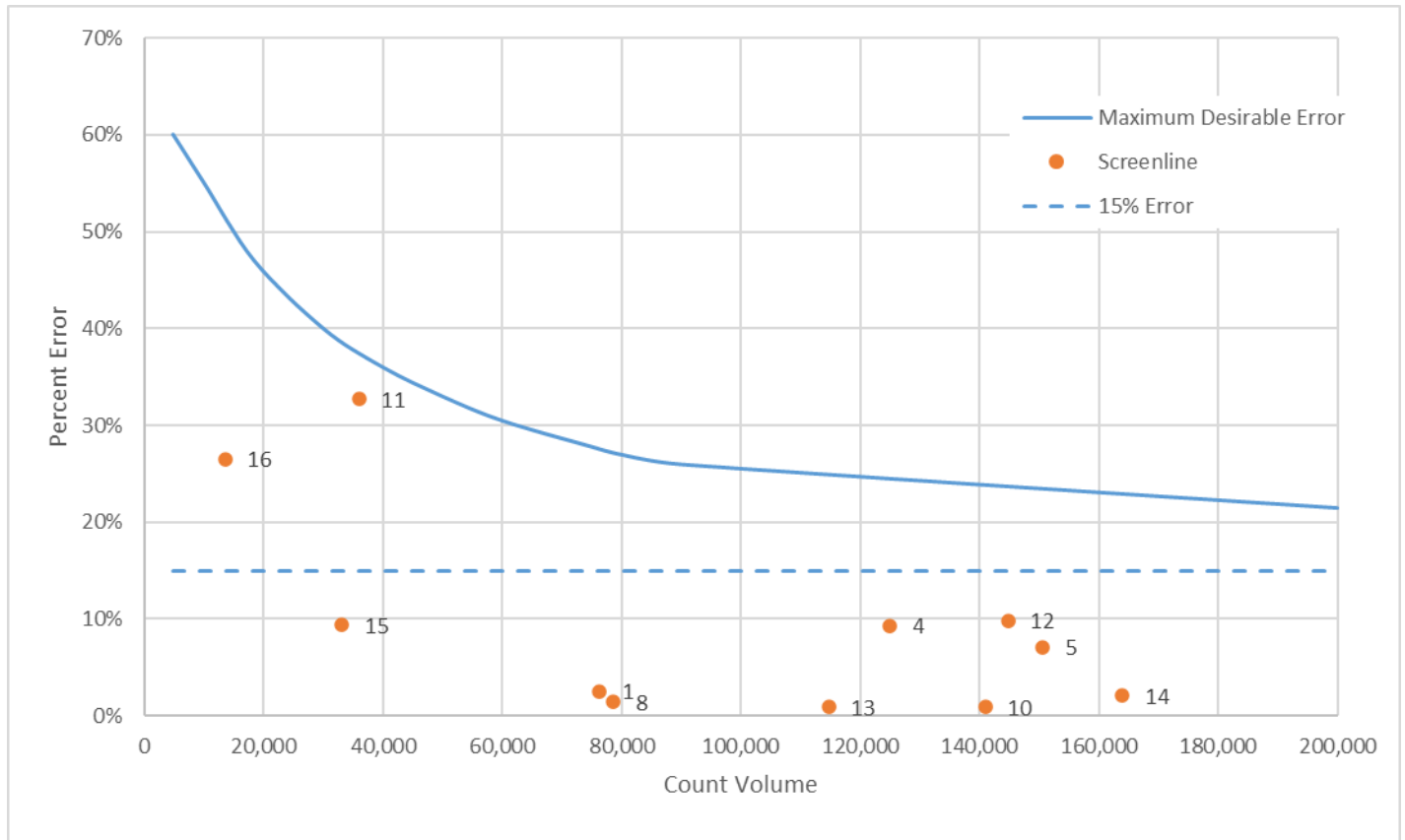

Figure 11.10 RMS Model Screenline Analysis



11.5 Transit Assignment Validation

Transit assignment has been validated to observed route boardings by the route groups shown in **Figure 11.11**. As shown in **Table 11.9**, the overall number of boardings is nearly identical to observed values. The Central/Northeast group is moderately under-predicted, with other groups slightly over-predicted. The County service provides rural connections to the Sun Metro system and is not concentrated in any one geographic area. While the percent error is high for the county system, further adjustments were not performed for the county route group since it carries a relatively small share of overall transit riders.

The transit assignment validation results show the RMS Model is sufficiently calibrated to support testing of transit alternatives and scenarios on a regional basis. The model is useful for comparative analysis of different transit improvements and accounts transit as part of the overall transportation system in the region. The model serves as a starting point for detailed transit planning activities, such as corridor studies or New Starts/Small Starts analysis. If the model is used for detailed transit planning, localized calibration and validation efforts should be conducted.

Table 11.9 Transit Assignment Results

Route Group	Observed	Modeled	Error	% Error
Eastside/Mission Valley	17,272	19,912	2,640	15%
Westside	10,118	11,030	911.7	9%
Central/Northeast	12,248	9,005	-3,243	-26%
Sun Metro Subtotal	39,638	39,947	309	1%
County	1,238	1,164	-74	-6%
SCRTD (New Mexico)	n/a	275	n/a	n/a
Total	40,876	41,386	n/a	n/a

Source: El Paso RMS Model and 2017 transit boardings data obtained from Sun Metro and the National Transit Database. Observed data unavailable for the subset of South Central Regional Transit District (SCRTD) routes in the RMS Model.

Figure 11.11 Route Group Definitions

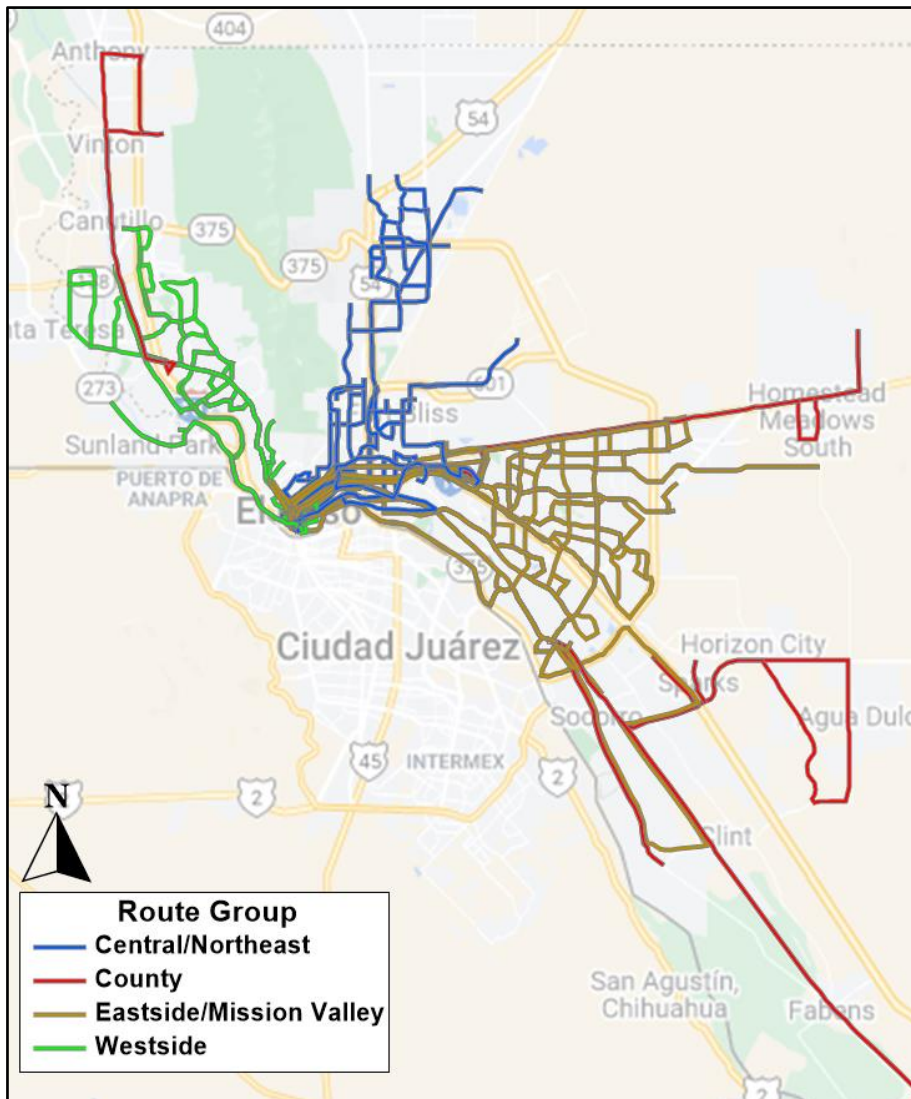

Appendix A. LOCUS Location Based Services Data

While household travel surveys collect rich information about the traveler and their travel behavior, they are expensive and time consuming to conduct and sample sizes are typically small. Practitioners have also noted declining participation rates in traditional surveys.

Location data collected passively from mobile devices, on the other hand, are becoming an increasingly valuable source of information about travel patterns. These data can provide detailed information about how people are moving, where they are going, and when their travel is occurring. These datasets are also massive in size, often containing millions of records collected over a period of months, rather than the typical 1- to 2-day travel diary often collected by travel surveys. Not only does this generate a larger overall sample, travel patterns can be tracked over the course of days, weeks, or even months to capture more frequent travel patterns. However, location data cannot provide all of the disaggregate household information available from household travel surveys.

A variety of passive mobile device data collection paradigms exist, including call detail records (CDR), Global Positioning Systems (GPS) data, and location-based services (LBS) data from smartphones. LBS data are the newest type of passively collected cell phone data, but are quickly becoming more ubiquitous.

LBS data are collected by GPS applications running either in the background or foreground on smartphones, where the device user has opted to allow access to the app to track the device's geographic location. The data are anonymized so that information cannot be tracked to a particular mobile phone number.

Cambridge Systematics performed a study for National Cooperative Highway Research Program (NCHRP) to estimate origin-destination (O-D) trip matrices with mobile data. The LBS product, LOCUS, used to support the El Paso model update efforts, was developed using analytics developed for the NCHRP study but has been refined to support modeling work.

The data contain a series of events for each smartphone device, where each event represents a cluster of time and location data points. The spacing of the events in the data is not regular; in some cases, events may be closely grouped with only small time gaps in between them, while in other cases, time gaps between events could be several hours or more. Time gaps depend on a variety of conditions, including the frequency with which the device is used and the types of apps running on the device.

Each event is classified as either a visit or a trajectory, depending on whether the device was stationary (resulting in a visit) or moving (resulting in a trajectory). For each event, several data fields exist, including start time, duration, and starting and ending coordinates. We process these events to identify trip stops, measure travel movements, and quantify travel demand.

Locus has previously been applied to support modeling work in metropolitan areas of varying size, and now for the El Paso region. The analytical framework is described below in greater detail.

Data Description

The data used for the El Paso region come from a dataset of mobile devices (including residents and visitors) observed in the modeling area. The data collection period includes the full year of 2019. As a consequence of this large sample size, detailed conclusions can be drawn about key aspects of travel, including O-D flows, time of day distribution, day of the week flows, and travel purpose.

Key Analytics Steps

Three key analytical steps were applied to take the trip data generated from the LBS dataset to convert into a usable dataset for use in travel model calibration and validation. These are described briefly below:

- **Identify Home and Regular Locations** – The first step in processing the raw location information was to filter trajectory events, identify activity stays, and infer trips. Once activity stays and trips were extracted for each device, home and work locations were inferred based on stay durations and time of day/day of the week frequencies.
- **Expand to Match Population and Employment Estimates** – Expansion methods were then applied to the processed LOCUS data to match El Paso population and employment estimates for the region. The weighted metrics provide estimates of person trips rather than index scores that could be biased.
- **Normalize Data to Develop Average Weekday and Weekend Day Travel Patterns** – Devices often provide a different number of valid/usable days. As a final step, multi-day travels were normalized by day of week for each device to capture typical weekday, Saturday, and Sunday daily travel patterns.

Appendix B. Transit Delay Parameters

Table B.1 Peak Local Transit Delay Factors

Functional Class	CBD (1)	CBD Fringe (2)	Urban (3)	Suburban (4)	Rural (5)
0 Centroid Connector	n/a	n/a	n/a	n/a	n/a
1 Freeway	0	0	0	0	0
2 Expressway	0	0	0	0	0
3 Principal Arterial	0	0	0	0	0
4 Minor Arterial	1.00	0.80	0.70	0.70	0.70
5 Collector	0.50	0.20	0.50	0.10	0.00
7 Local	0.50	0.20	0.10	0.10	0.10
20 Ramp	0.50	0.30	0.30	0.30	0.30

Table B.2 Peak Express Transit Delay Factors

Functional Class	CBD (1)	CBD Fringe (2)	Urban (3)	Suburban (4)	Rural (5)
0 Centroid Connector	n/a	n/a	n/a	n/a	n/a
1 Freeway	0	0	0	0	0
2 Expressway	0	0	0	0	0
3 Principal Arterial	0	0	0	0	0
4 Minor Arterial	0.50	0.10	0.10	0	0
5 Collector	2.50	2.50	2.50	0	0
7 Local	0.10	0.10	0.10	0.10	0
20 Ramp	0.50	0.10	0.50	0	0

Table B.3 Peak Premium Transit Delay Factors

Functional Class	CBD (1)	CBD Fringe (2)	Urban (3)	Suburban (4)	Rural (5)
0 Centroid Connector	n/a	n/a	n/a	n/a	n/a
1 Freeway	0	0	0	0	0
2 Expressway	0	0	0	0	0
3 Principal Arterial	0	0	0	0	0
4 Minor Arterial	0.45	0.09	0.09	0	0
5 Collector	0.45	0.18	0.45	0	0
7 Local	0.09	0.09	0.09	0.09	0
20 Ramp	0.45	0.09	0.27	0	0

Table B.4 Off-Peak Local Transit Delay Factors

Functional Class	CBD (1)	CBD Fringe (2)	Urban (3)	Suburban (4)	Rural (5)
0 Centroid Connector	n/a	n/a	n/a	n/a	n/a
1 Freeway	0	0	0	0	0
2 Expressway	0	0	0	0	0
3 Principal Arterial	0	0	0	0	0
4 Minor Arterial	1.00	1.00	1.00	0.20	0.20
5 Collector	0.50	0.50	0.50	0.10	0
7 Local	0.50	0.50	0.10	0.10	0.10
20 Ramp	0.50	0.50	0.30	0.10	0.10

Table B.5 Off-Peak Express Transit Delay Factors

Functional Class	CBD (1)	CBD Fringe (2)	Urban (3)	Suburban (4)	Rural (5)
0 Centroid Connector	n/a	n/a	n/a	n/a	n/a
1 Freeway	0	0	0	0	0
2 Expressway	0	0	0	0	0
3 Principal Arterial	0	0	0	0	0
4 Minor Arterial	0.50	0.10	0.10	0	0
5 Collector	2.50	2.50	2.80	0	0
7 Local	0.10	0.10	0.10	0.10	0
20 Ramp	0.50	0.10	0.50	0	0

Table B.6 Off-Peak Premium Transit Delay Factors

Functional Class	CBD (1)	CBD Fringe (2)	Urban (3)	Suburban (4)	Rural (5)
0 Centroid Connector	n/a	n/a	n/a	n/a	n/a
1 Freeway	0	0	0	0	0
2 Expressway	0	0	0	0	0
3 Principal Arterial	0	0	0	0	0
4 Minor Arterial	0.45	0.09	0.09	0	0
5 Collector	0.45	0.45	0.45	0	0
7 Local	0.09	0.09	0.09	0.09	0
20 Ramp	0.45	0.09	0.27	0	0

Appendix C. NAICS Codes

Table C.1 Employment Type Definition

Employment Type	2017 NAICS	Description
Basic	11	Agriculture, Forestry, Fishing and Hunting
	21	Mining, Quarrying, and Oil and Gas Extraction
	22	Utilities
	23	Construction
	31-33	Manufacturing
	42	Wholesale Trade
	48-49	Transportation and Warehousing
	5111	Newspaper, Periodical, Book, and Directory Publishers
	5112	Software Publishers
	512	Motion Picture and Sound Recording Industries
	5151	Radio and Television Broadcasting
	5152	Cable and Other Subscription Programming
	5174	Satellite Telecommunications
	92	Active Duty Personnel
	Service	5171
5172		Wireless Telecommunications Carriers (except Satellite)
5179		Other Telecommunications
518		Data Processing, Hosting, and Related Services
519		Other Information Services
52		Finance and Insurance
53		Real Estate and Rental and Leasing
54		Professional, Scientific, and Technical Services
55		Management of Companies and Enterprises
56		Administrative and Support and Waste Management and Remediation Services
6114		Business Schools and Computer and Management Training
6115		Technical and Trade Schools
6116		Other Schools and Instruction
6117		Educational Support Services
62		Health Care and Social Assistance
81	Other Services (except Public Administration)	
92	Public Administration (except active duty personnel)	
721	Accommodation	
Retail	44-45	Retail Trade

Employment Type	2017 NAICS	Description
	491	Postal Service
	51213	Motion Picture and Video Exhibition
	71	Arts, Entertainment, and Recreation
	722	Food Services and Drinking Places
Education 1	6111	Elementary and Secondary Schools
Education 2	6112	Junior Colleges
	6113	Colleges, Universities, and Professional Schools
